

AA 50/5 T2 5,5kW (255150120)

GENERAL DATA



HIGH PRESSURE WITH ALUMINIUM BACKWARD IMPELLER

MANUFACTURING FEATURES:

- Rolling steel sheet housing.
- Fully welded housing.
- High efficiency simple inlet backward impeller with self-cleaning system manufactured in cast aluminium.
- Polyester powder finishing coat.
- Standard asynchronous squirrel-cage motor with IP-55 protection and class F insulation. Standard voltages 230/400V 50Hz motors up to 4kW and 400/690V 50Hz for higher powers.

- Available positions (to be indicated in case of order): LG270, LG0, LG45, LG90, LG135, LG180, LG225, LG315.
- The indicated codes correspond to the model in position LG270

APPLICATIONS:

Designed for inline installation, they are suitable for:

- Industrial applications, extraction or injection of air.
- Cooling of machines and parts.
- Clean air transport.
- Exhaust after filters, separators and cyclones.
- Pneumatic transport.
- Maximum working temperature: carried air: 130°C, ambient 60°C.

UNDER REQUEST:

- 60Hz fans and special voltages.
- 2 speed motors.

PERFORMANCE CURVE

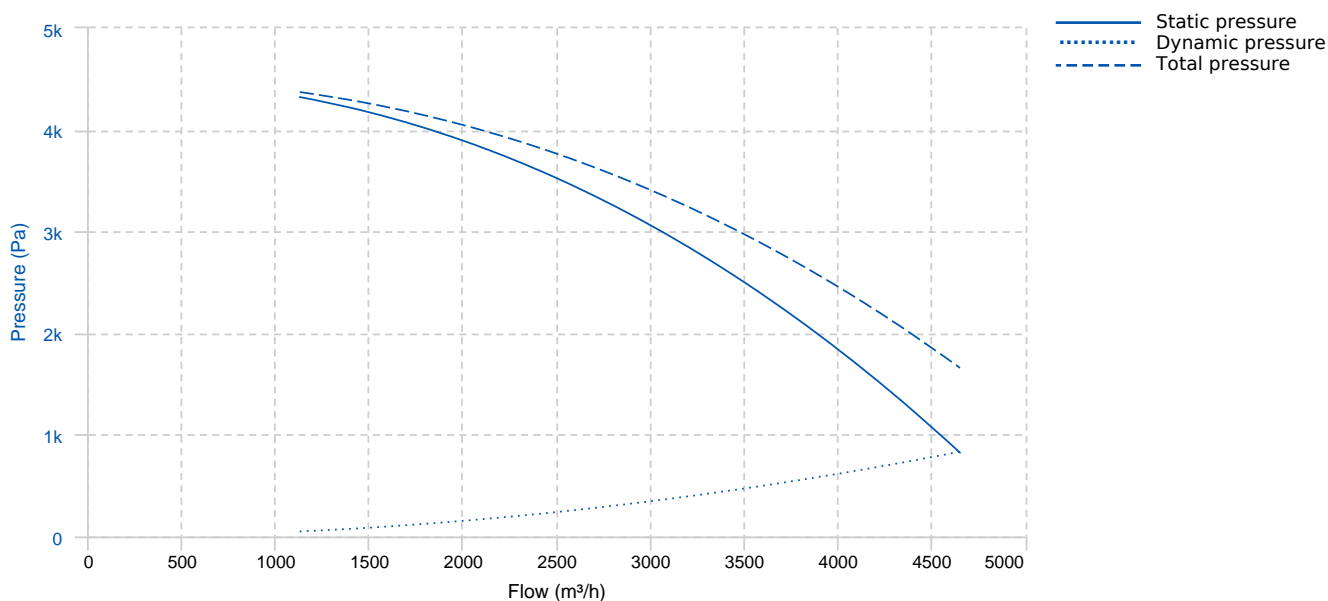

TECHNICAL DATA

| Fan | | | | | | | |
|-------|--------|----------------|-------|----------------|------------------------|---------------|--------|
| RPM | 2910 | Approx. weight | 92 kg | Max. Flow | 4660 m ³ /h | | |
| Motor | | | | | | | |
| Power | 5,5 kW | RPM | 2910 | I max. (400V) | 10,6 A | I max. (690V) | 6,14 A |
| Size | 132S | Approx. weight | 68 kg | Efficiency (%) | 89.2 % | FP | 0.85 |

ERP DATA

| Fan data sheet | | |
|-------------------------------------|---|-----------------------|
| Fan type | Centrifugal fan backward blades with casing | |
| Installation category | B: Inlet free, Ducted outlet | |
| Efficiency category | Total | |
| The fan has to be installed with VF | No | |
| Motor power (kW) | 5.5 | |
| | Fan values | ERP Requirements 2015 |
| Max. efficiency (%) | 61.9 | 60.35 |
| Efficiency grade (N) | 65.54 | 64 |
| Pabs (kW) | 4.493 | |
| Flow (m ³ /h) | 2554.83 | |
| Total pressure (Pa) | 3729.89 | |
| Speed (m/s) | 2910 | |
| Specific ratio | 1.00 | |

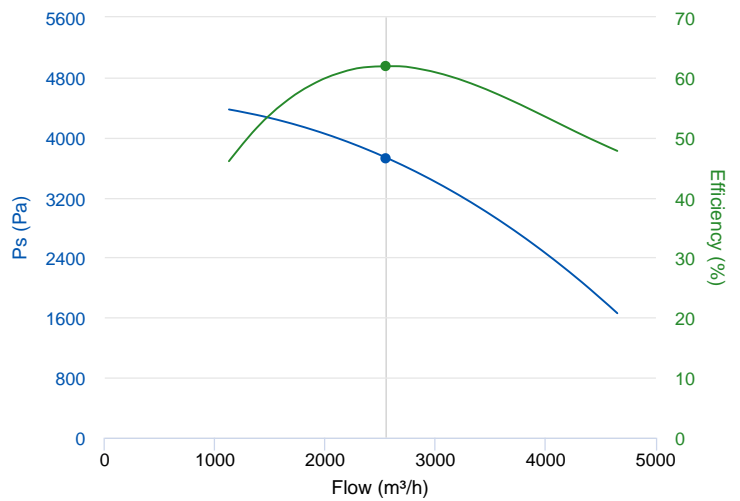

DIMENSIONS

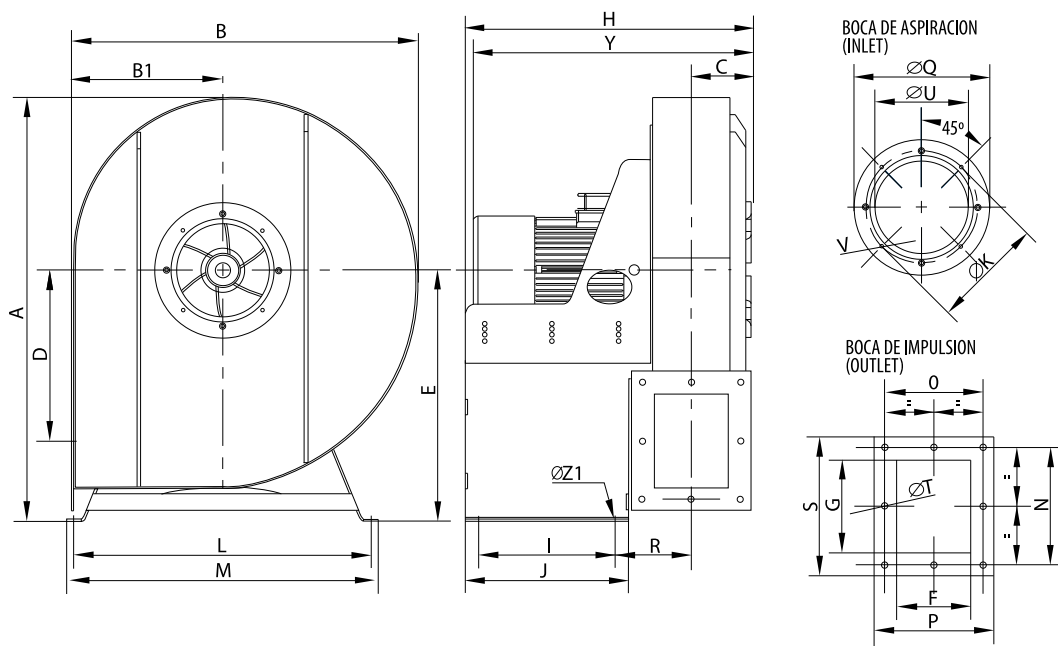

Dimensions (mm)

| | | | | | | | | | |
|----|-----|----|-------|----|--------|---|-----|-----|-----|
| A | 877 | B | 716,5 | B1 | 307,25 | C | 121 | D | 358 |
| E | 520 | F | 150 | G | 200 | H | 583 | I | 275 |
| J | 325 | KØ | 258 | L | 589 | M | 614 | N | 256 |
| O | 206 | P | 246 | QØ | 292 | R | 162 | S | 280 |
| TØ | 11 | UØ | 210 | V | M6 | Y | 603 | Z1Ø | 11 |

WIRING DIAGRAM

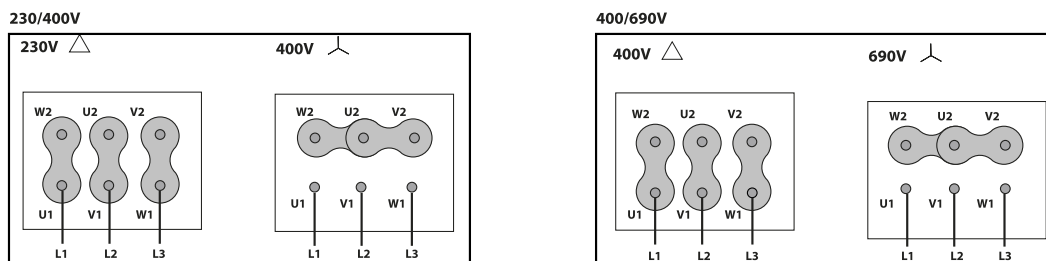

ACCESSORIES



SAFETY SWITCH
INT 25 3P A
REF: INT253PA



INLET PROTECTION GUARD FOR CENTRIFUGAL FANS
RA 22/9
REF: A-253201901



CIRCULAR OUTLET CONNECTION FLANGE
EI 50/5
REF: 962500112



ANTI-VIBRATING FLANGE 400°/2H
BA-400 25
REF: 960002051



ANTI-VIBRATION JOINT
JE 45
REF: 300719201



CONNECTION FLANGE
AC 225
REF: 960003207



OUTLET PROTECTION GUARD
RBS 50/5
REF: A-960000372



FREQUENCY SPEED CONTROLLER
SFC 400 III 12A *
REF: SFC400III12



ANTI-VIBRATION RUBBER BLOCK
AVR (GENERIC)



ANTI-VIBRATION SPRING BLOCK
AVS (GENERIC)



ACOUSTIC CABINS FOR CENTRIFUGAL FANS
AB (GENERIC)

SPARE PARTS

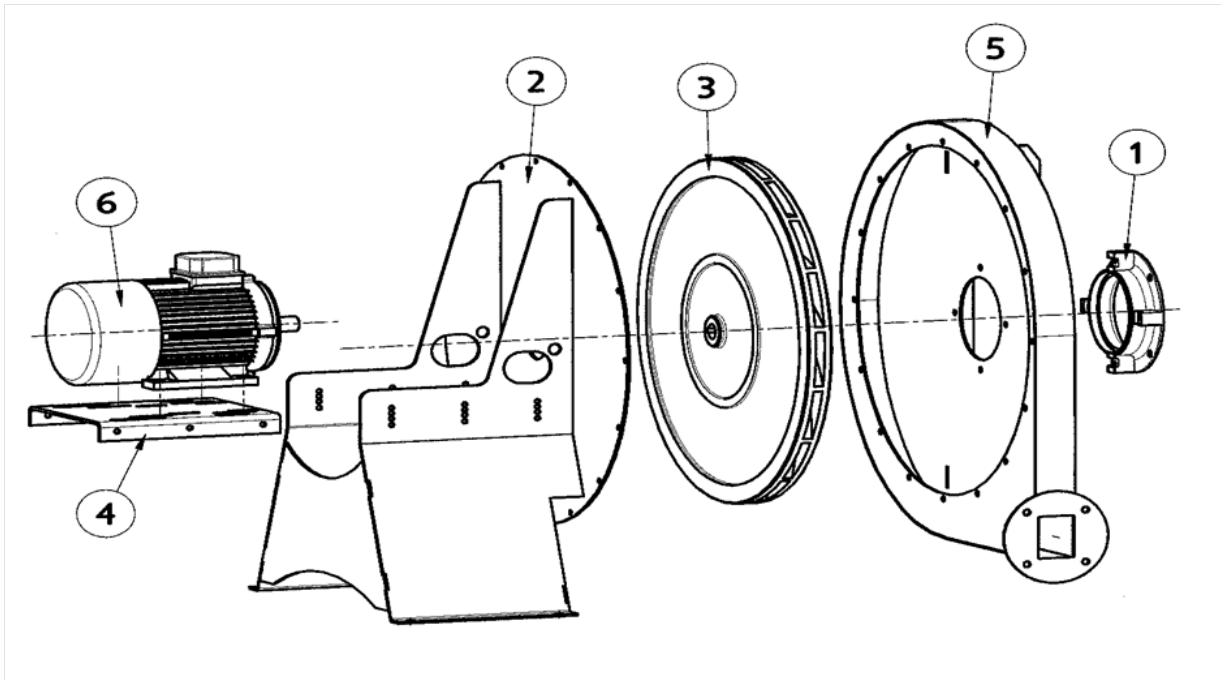

| | Code | Model | Qty |
|---|-------------|--------------------------------------|-----|
| 1 | R-255151681 | INLET CONE AA 50/5 | x1 |
| 2 | R-255159204 | BASE SUPPORT MOTOR AA50/5 | x1 |
| 3 | R-255153652 | TURBINE AA 50/5 T2 5,5kW LG | x1 |
| 4 | R-243631754 | MOTOR SUPPORT MBR-MBRF63,71,45P/R(A) | x1 |
| 5 | R-255159421 | CASING AA50/5 | x1 |



| | Code | Model | Qty |
|---|-----------|----------------------------|-----|
| 6 | 721001072 | MOTOR 5,5kW T2 B3 400/690V | x1 |