

AA 59 T2 3kW (255350163)

GENERAL DATA



HIGH PRESSURE WITH ALUMINIUM FORWARD IMPELLER

MANUFACTURING FEATURES:

- Rolling steel sheet housing.
 - Fully welded housing.
 - High efficiency simple inlet forward curved impeller manufactured in cast aluminium.
 - Polyester powder finishing coat.
 - Standard asynchronous squirrel-cage motor with IP-55 protection and class F insulation.
- Standard voltages 230/400V 50Hz motors up to 4kW and 400/690V 50Hz for higher powers.

- Available positions (to be indicated in case of order): LG270, LG0, LG45, LG90, LG135, LG180, LG225, LG315.
- The indicated codes correspond to the model in position LG270

APPLICATIONS:

Designed for inline installation, they are suitable for:

- Industrial applications, extraction or injection of air.
- Cooling of machines and parts.
- Clean air transport.
- Exhaust after filters, separators and cyclones.
- Pneumatic transport.
- Maximum working temperature: carried air: 130°C, ambient 60°C.

UNDER REQUEST:

- 60Hz fans and special voltages.
- 2 speed motors.

PERFORMANCE CURVE

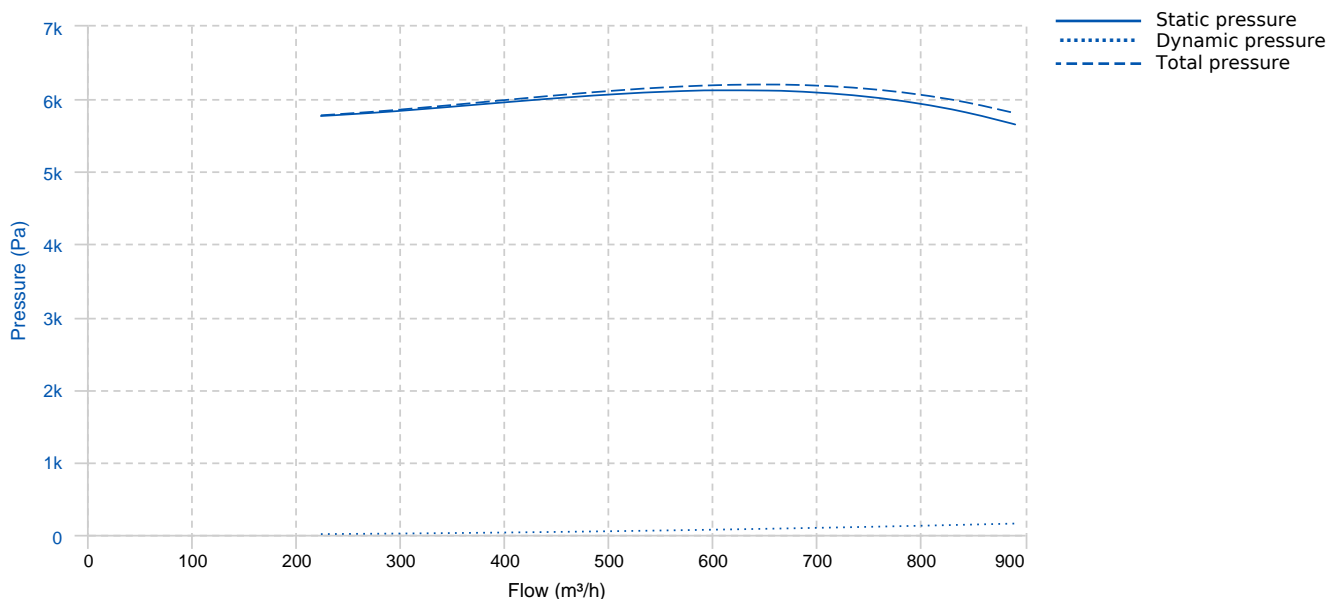

TECHNICAL DATA

Fan							
RPM	2880	Approx. weight	77 kg	Max. Flow	900 m ³ /h		
Motor							
Power	3 kW	RPM	2880	I max. (230V)	10,3 A	I max. (400V)	5,92 A
Size	100L	Approx. weight	38.5 kg	Efficiency (%)	87.1 %	FP	0.86

ERP DATA

Fan data sheet		
Fan type	Centrifugal fan radial or forward blades	
Installation category	B: Inlet free, Ducted outlet	
Efficiency category	Total	
The fan has to be installed with VF	No	
Motor power (kW)	3	
	Fan values	ERP Requirements 2015
Max. efficiency (%)	51.41	46.14
Efficiency grade (N)	54.27	49
Pabs (kW)	3.546	
Flow (m ³ /h)	890	
Total pressure (Pa)	5808.5	
Speed (m/s)	2880	
Specific ratio	1.00	

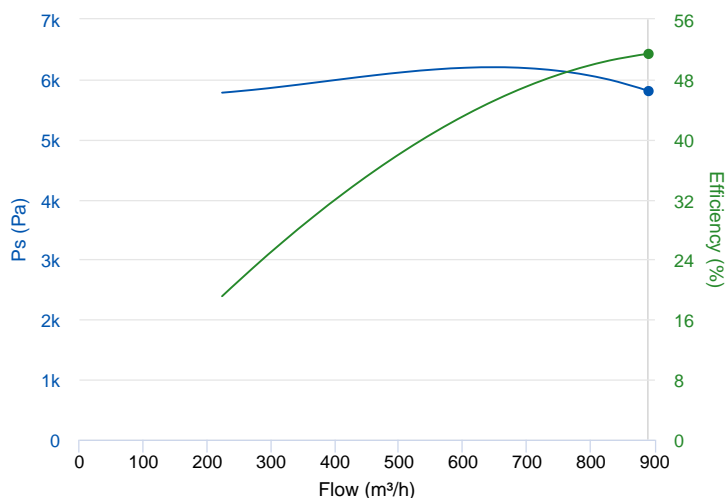

DIMENSIONS

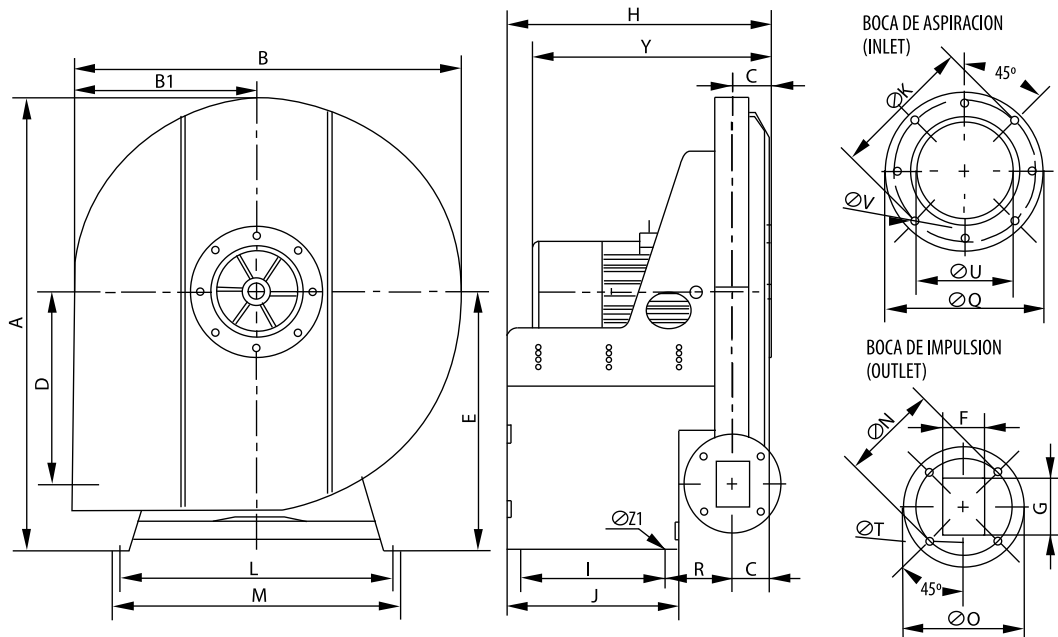

Dimensions (mm)

A	789	B	679	B1	321	C	71,5	D	335
E	451	F	60	G	80	H	468,5	I	250
J	300	KØ	205	L	475	M	500	NØ	140
OØ	175	QØ	230	R	122	TØ	11	UØ	140
VØ	12	Y	433,5	Z1	11				

WIRING DIAGRAM

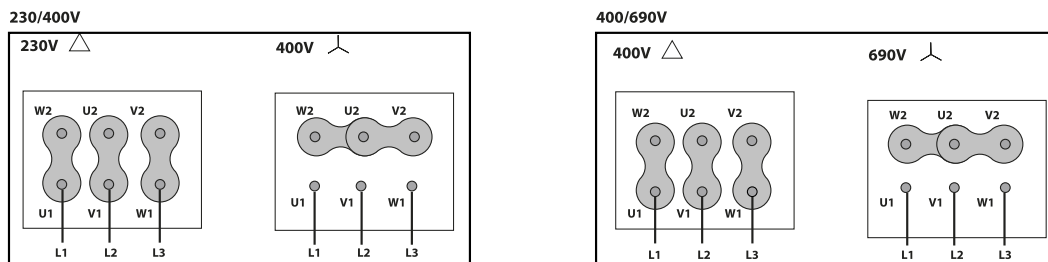

ACCESSORIES



SAFETY SWITCH
INT 25 3P A
REF: INT253PA



INLET PROTECTION GUARD FOR CENTRIFUGAL FANS
RA 18/7
REF: A-253171901



CIRCULAR OUTLET CONNECTION FLANGE
EI 47
REF: 962470111



ANTI-VIBRATION JOINT
JE 45
REF: 300719201



OUTLET PROTECTION GUARD
RBS 59
REF: A-960000375



ANTI-VIBRATION RUBBER BLOCK
AVR (GENERIC)



ACOUSTIC CABINS FOR CENTRIFUGAL FANS
AB (GENERIC)



ANTI-VIBRATING FLANGE 400°/2H
BA-400 20
REF: 960002066



CONNECTION FLANGE
AC 175
REF: 960003205



FREQUENCY SPEED CONTROLLER
SFC 400 III 8A *
REF: SFC400III8



ANTI-VIBRATION SPRING BLOCK
AVS (GENERIC)

SPARE PARTS

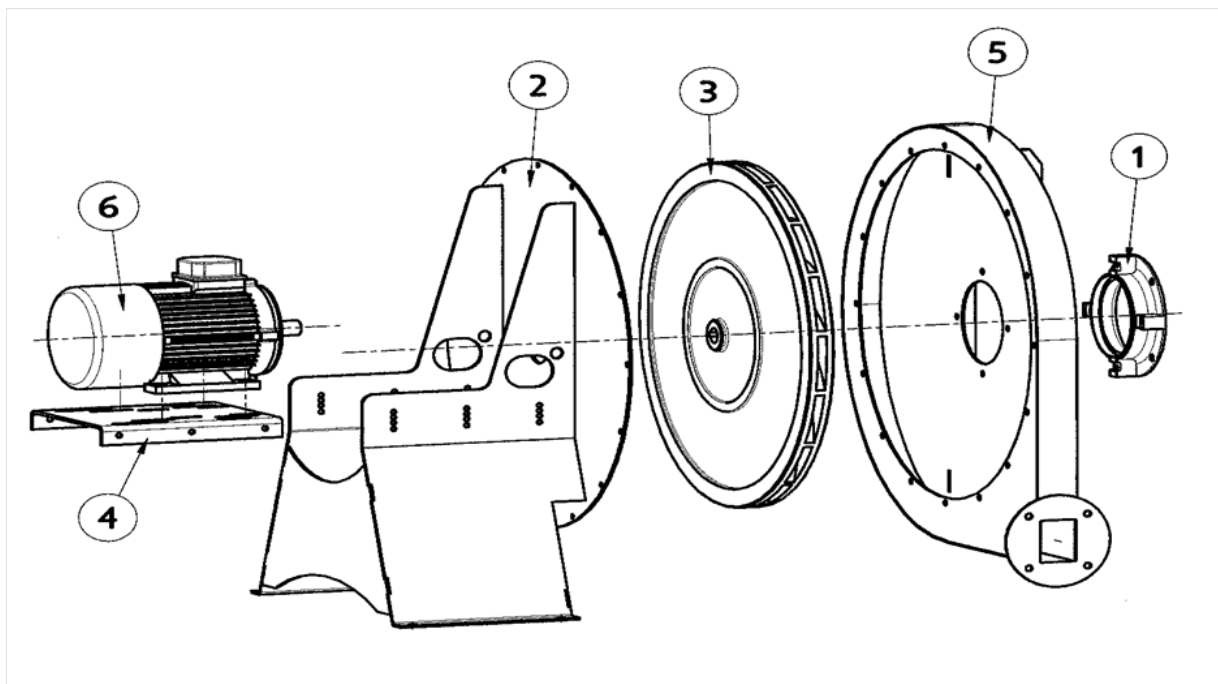

	Code	Model	Qty
1	R-255351681	INLET CONE AA59-66-70	x1
2	R-255359204	BASE SUPPORT MOTOR AA59	x1
3	R-255353652	TURBINE AA 59 T2 3kW LG	x1
4	R-243401753	MOTOR SUPPORT MBR-MBRF31aI56(A)	x1
5	R-255359421	CASING AA59	x1



	Code	Model	Qty
6	721001059	MOTOR 3KW T2 B3 230/400V	x1