

AAVA 350/P T2 0,37kW (std) (502403515)

GENERAL DATA



HIGH PRESSURE WITH BACKWARD IMPELLER

MANUFACTURING FEATURES:

- Fan made of Fe360 sheet. The fan paint finish is based on a Qualicoat polyester powder coating stoved at 200°C, with an average film thickness of 70 microns. Average heat resistance of coating is 180°C with peaks of 200°C.
- Fully welded housing.
- High efficiency simple inlet backward impeller with self-cleaning system made of Fe360 sheet statically and dynamically balanced. Impellers are painted with polyester primer that resists temperatures up to 300°C.
- Standard asynchronous squirrel-cage motor with IP-55 protection and class F insulation. Manufactured with standard voltages: 230/400V 50Hz in three phase motors up to 4kW and 400/690V 50Hz for higher powers.
- It allows adjusting the orientation locally from models 220 to 630. Models sizes from 710 to 1000 size the orientation is fixed.

- Available positions (to be indicated in case of order): LG270, LG0, LG45, LG90, LG135, LG180, LG225, LG315, RD0, RD45, RD90, RD135, RD180, RD225, RD270, RD315.
- The indicated codes correspond to the model in position LG270

APPLICATIONS:

Designed for inline installation, they are suitable for:

- Industrial applications, extraction or injection of air.
- Cooling of machines and parts.
- Clean air transport.
- Exhaust after filters, separators and cyclones.
- Pneumatic transport.
- Maximum working temperature: carried air: 130°C, ambient: 60°C.

UNDER REQUEST

- Fans for 60Hz and special voltages.
- 2 speed motor.
- C4 coating painting
- Hot dip galvanized
- Special steel (Cor-Ten A, Hardox...)
- Inox 304 (normal or electropolished finish)
- Inox 316 (normal or electropolished finish)
- Cooling wheel
- Anticaloric paint
- Reinforced housing
- Fully welded housing (waterproof)
- Insulated housing
- Split casing (for big sizes)
- Inspection door to facilitate maintenance and cleaning
- Drain plug.
- Airtight axle
- Frontal foot
- Double suction flange
- Available in non-sparking air passage and standard motor.
- Other brands of motors.

PERFORMANCE CURVE

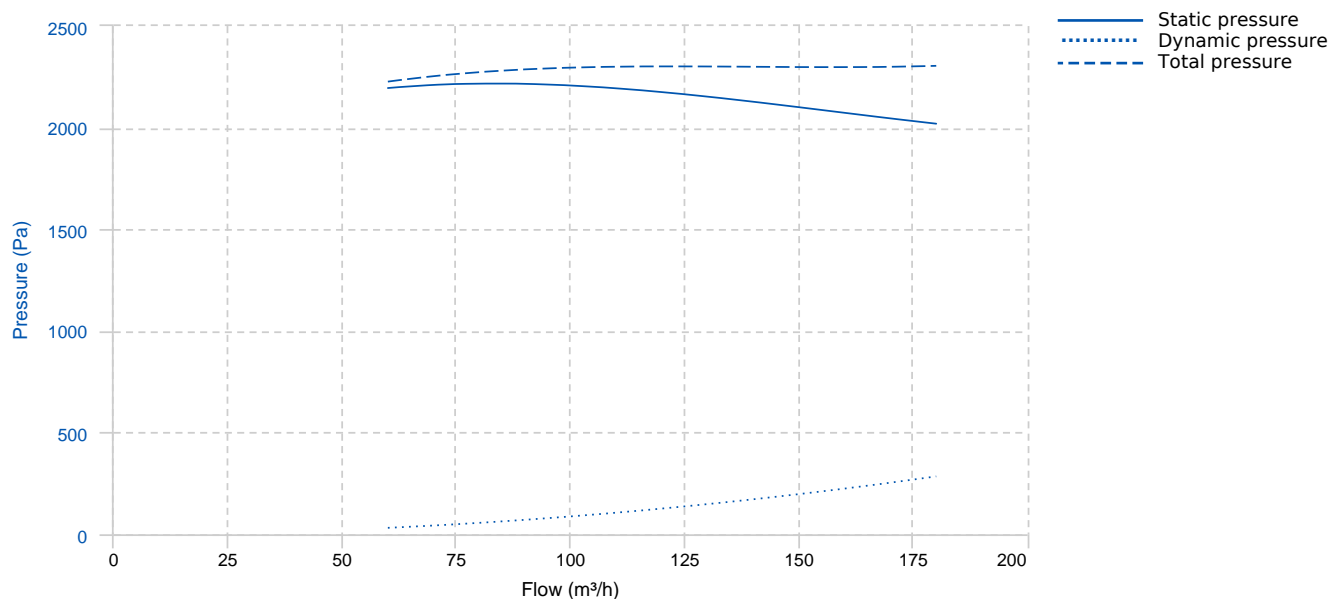

TECHNICAL DATA

Fan							
RPM	2800	Approx. weight	33 kg	Max. Flow	190 m³/h		
Motor							
Power	0,37 kW	RPM	2800	I max. (230V)	1,58 A	I max. (400V)	0,91 A
Size	71	Approx. weight	5.7 kg				

DIMENSIONS

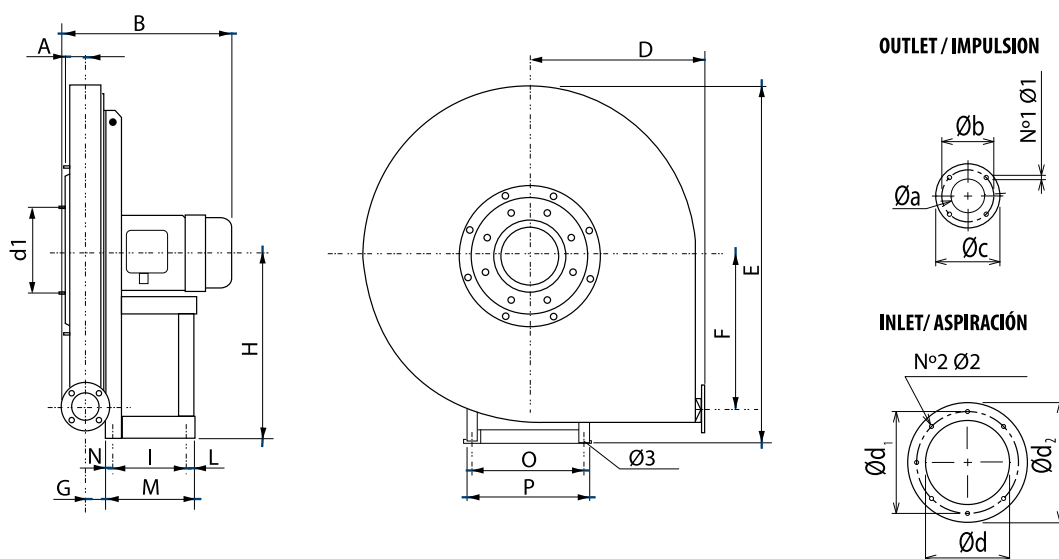

Dimensions (mm)

A	34	B	310	D	270	E	550	F	220
G	30	H	280	I	121	L	23	M	189
N	45	N1xØ1	4x8,5	N2xØ2	Nº8 M6x20	O	203	P	225
Ø3	10	Øa	54	Øb	84	Øc	104	Ød	145
Ød1	182	Ød2	215						

WIRING DIAGRAM

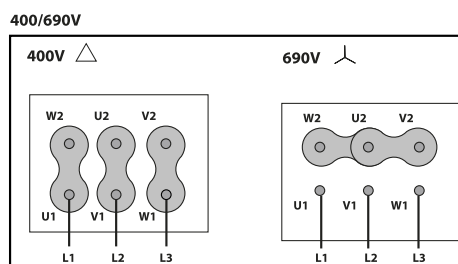
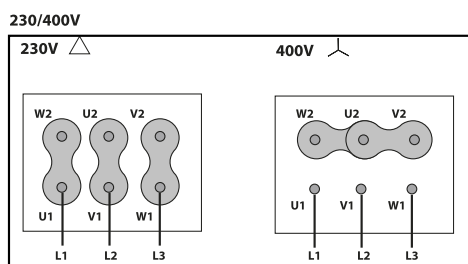

ACCESSORIES



SAFETY SWITCH
INT 25 3P A
REF: INT253PA



ANTI-VIBRATION JOINT
JE 45
REF: 300719201



INLET PROTECTION GUARD FOR CENTRIFUGAL FANS
RA 145x8
REF: 510001400



CIRCULAR OUTLET CONNECTION FLANGE
EI 54x4-54
REF: 510200500



FREQUENCY SPEED CONTROLLER
SFC 230 I 2,5A *
REF: SFC230I003



ANTI-VIBRATING FLANGE 400º/2H
BA-400 15/16
REF: 960002067



CONNECTION FLANGE
AC 150
REF: 960003204



OUTLET PROTECTION GUARD FOR FANS
RI 54x4
REF: 510100500



FRONTAL FEET SUPORT
FS 350
REF: *GH-FS350



FREQUENCY SPEED CONTROLLER
SFC 400 III 1,2A *
REF: SFC400III1



**ANTI-VIBRATION RUBBER BLOCK
AVR (GENERIC)**



**ANTI-VIBRATION SPRING BLOCK
AVS (GENERIC)**



**ACOUSTIC CABINS FOR CENTRIFUGAL FANS
AB (GENERIC)**

SPARE PARTS

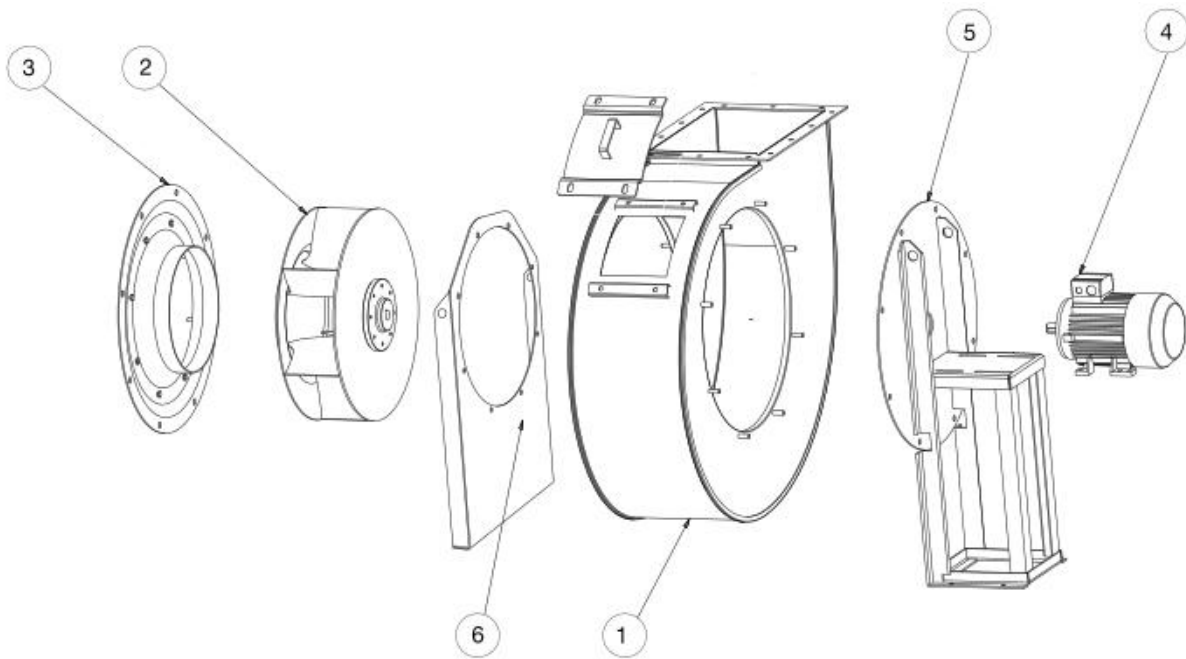

	Code	Model	Qty
2	T02403515	TURBINE AAVA 350/P LG	x1
3	505603500SP04	INLET CONE AAVA-AATVA 350/P	x1
4	721001022	MOTOR 0,37kW T2 B3 230/400V	x1