

BOX RLF 500 T4 1,5kW (241520186)

GENERAL DATA



BACKWARD CURVED CENTRIFUGAL FAN IN SOUNDPROOF CABINET 400°C/2H

MANUFACTURING FEATURES

- Box manufactured in galvanised steel sheet.
- Circular inlet flange.
- Backward impeller with self-cleaning system, direct coupling motor.
- Standard asynchronous squirrel-cage motor with IP-55 protection and Class H insulation type 400°C/2h .
- Manufactured with standard voltages: 400V(Y) 50Hz in three phase motors up to 3kW and 400V(D) 50Hz for higher powers and 400V for 2 speed motors.
- Exchangeable pannels
- Open drive.

APPLICATIONS

Designed for inline installation, they are suitable for:

- Air renewal in buildings and industries.
- Maximum working temperature: 60°C.
- Removing smoke in case of fire. The motor inside the hazardous area (400 ° C / 2 h)

Official homologation by the European laboratory APPLUS according to EN 12101-3:2015
Certification Nr: 0370-CPR-0582

PERFORMANCE CURVE

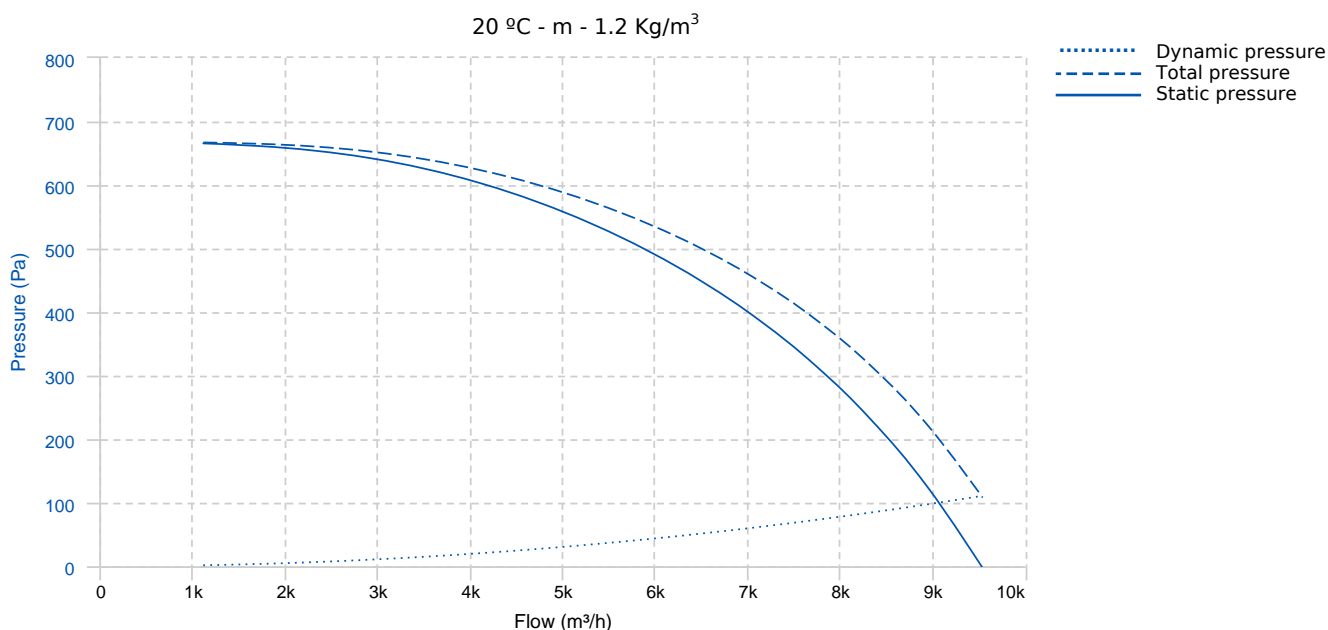

TECHNICAL DATA

Fan							
RPM	1450	Approx. weight	147 kg	Max. Flow	9540 m³/h		
Motor							
Power	1,5 kW	RPM	1450	I max. (230V)	5,9 A	I max. (400V)	3,4 A
Size	90	Approx. weight	30 kg	Efficiency (%)	85.3 %	FP	0.77

ERP DATA

Fan data sheet		
Fan type	Unit for non-residential ventilation (LOT 6)	
Typology	Unidirectional	
reports.other	None	
Type of driver	None	
Motor power (kW)	1.5	
	Fan values	ERP Requirements 2018
Max. efficiency (%)	57.05	44.54
Effic. Heat recovery (%)	-	
Pabs (kW)	1.506	
Flow (m³/h)	5818.97	
Static pressure (Pa)	503.85	
Speed (m/s)	8.3	
SFP (W/m3/s)	931.86	

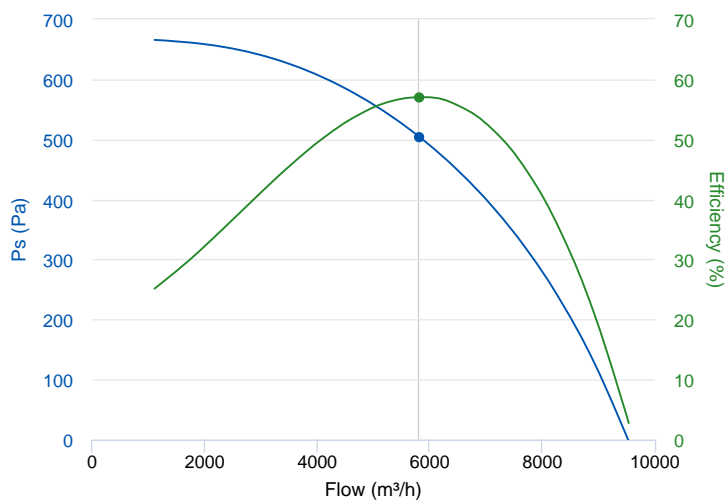

DIMENSIONS

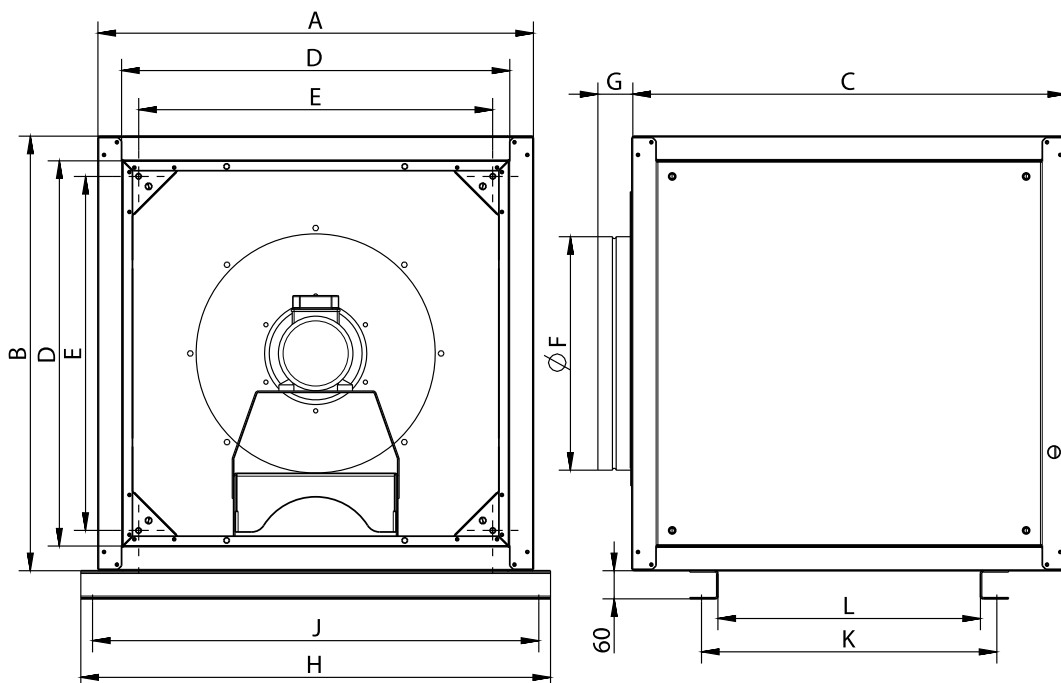

Dimensions (mm)

A	925	B	925	C	925	D	821	E	753
G	74	H	1127	J	1077	K	753	L	683
ØF	498								

WIRING DIAGRAM

230V 

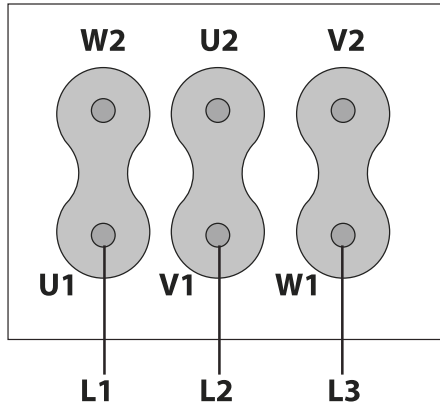

400V 

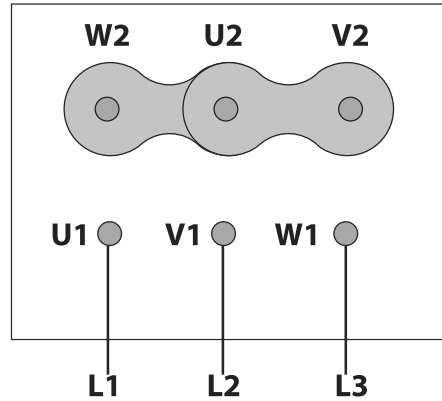

ACCESSORIES



SAFETY SWITCH
INT 25 3P A
REF: INT253PA



ANTI-VIBRATING FLANGE 400^o/2H
BA-400 50
REF: 960002064



ANTI-VIBRATION JOINT
JE 45
REF: A-300719201



INLET/OUTLET ROUND COVER
TIAC 50
REF: 960001950



CIRCULAR SILENCER
SIL-C 500/500
REF: 960050050

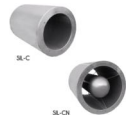

CIRCULAR SILENCER
SIL-C 500/750
REF: 960050075



CIRCULAR SILENCER
SIL-CN 500/500
REF: 961050050



CIRCULAR SILENCER
SIL-CN 500/750
REF: 961050075



CIRCULAR SILENCER
SIL-CN 500/1000
REF: 961050100



SAFETY SWITCH FOR 400^oC/2h
INT 400 25A 3P
REF: 508902501



FREQUENCY SPEED CONTROLLER
SFC 400 III 3,6A *
REF: SFC400III4

SPARE PARTS

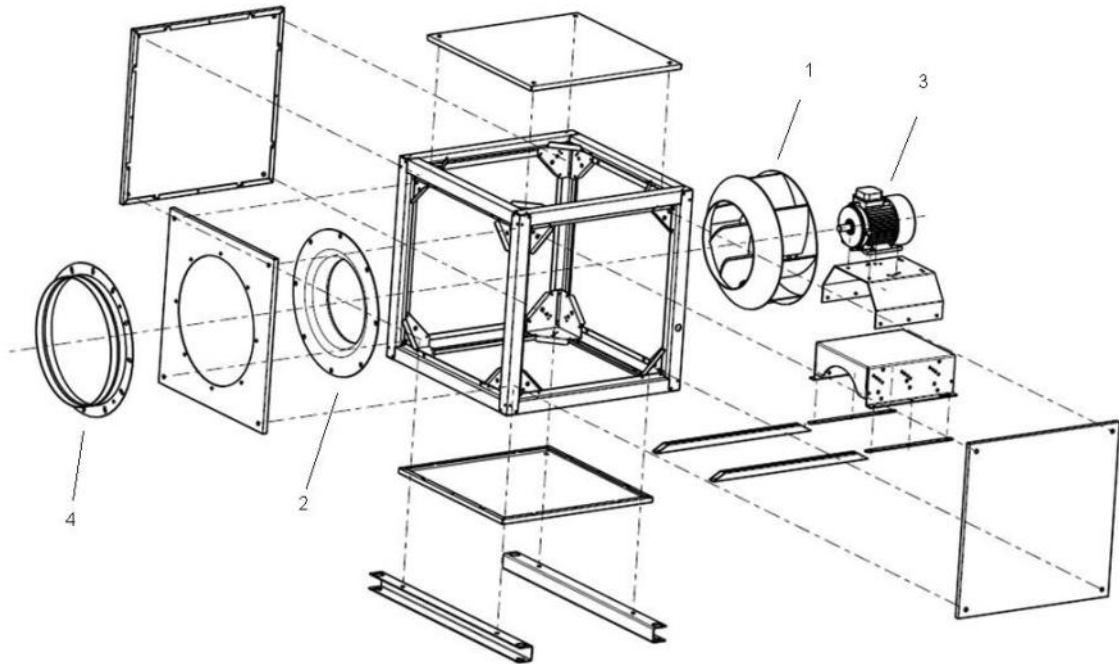

	Code	Model	Qty
3	721881156	MOTOR 1,5KW T4 B3 400G	x1
4	960003214	FLANGE AC-500	x1