

# HJB 110 T4 0,75KW (509111044)

## GENERAL DATA



BELT DRIVE AXIAL FAN FOR HUGE AIR FLOW

MANUFACTURING FEATURES:

- Completely made of galvanized steel sheet.
  - Equipped with gravity shutter.
  - Stainless steel impeller (AISI 430).
  - Protection grid on pulley area.
  - Standard asynchronous squirrel-cage motor with IP-55 protection and class F insulation.
- Manufactured with standard voltage: 230/400V 50Hz IE3
- Internal wiring box. Inspection door for motor access.

APPLICATIONS:

Designed for wall assembly, they are suitable for:

- Air renewal in buildings and industries.
- Farms and greenhouses.
- Maximum working temperature: 50°C.

UNDER REQUEST

Option 60Hz

## PERFORMANCE CURVE

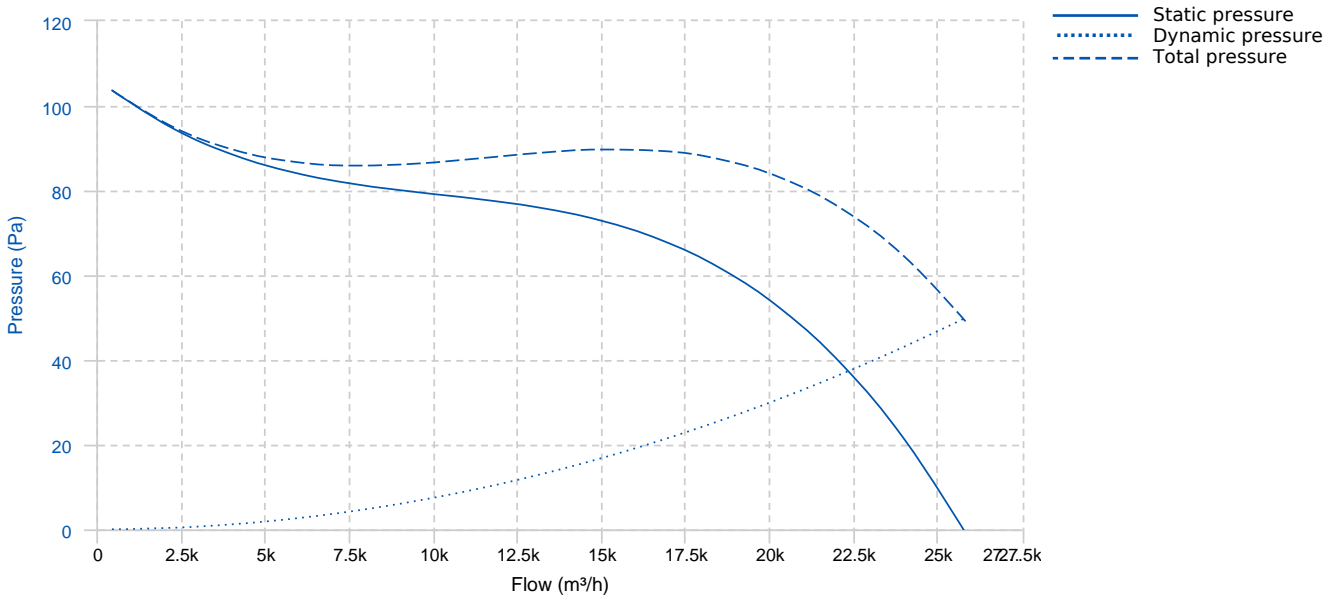

## TECHNICAL DATA

Fan							
RPM	1450	Approx. weight	88 kg	Max. Flow	25800 m³/h		
Motor							
Power	0,75 kW	RPM	1450	I max. (230V)	3,5 A	I max. (400V)	2 A

## Motor

Size	80	Approx. weight	9.5 kg	Efficiency (%)	80.5 %	FP	0. 676000000000 0005
------	----	----------------	--------	----------------	--------	----	----------------------------

## DIMENSIONS

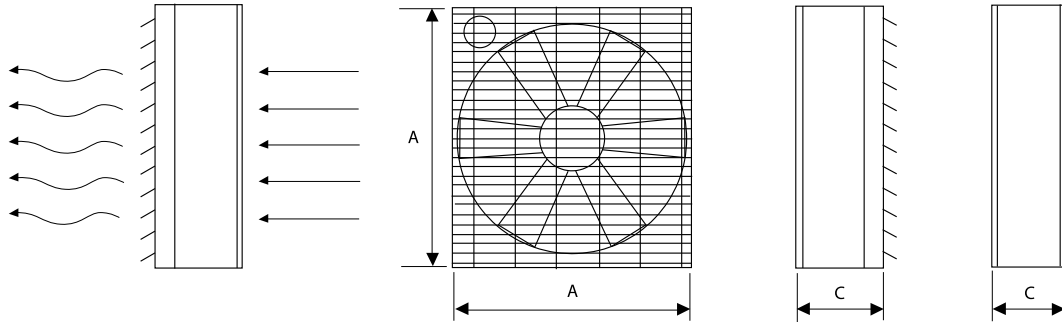

## Dimensions (mm)

A	1100	C	400
---	------	---	-----

## WIRING DIAGRAM

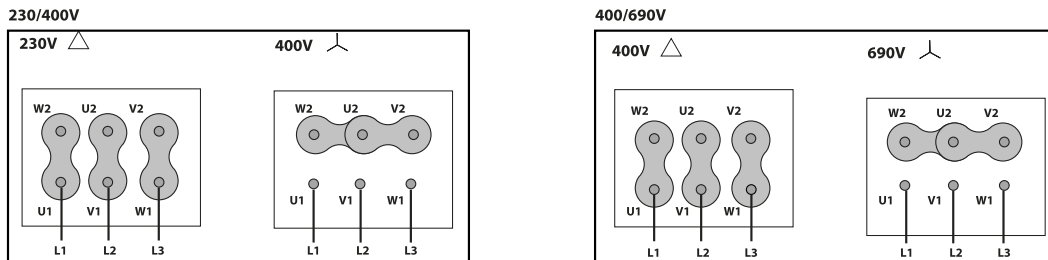

## ACCESSORIES



**SAFETY SWITCH**  
**INT 25 3P A**  
**REF: INT253PA**

**SPARE PARTS**

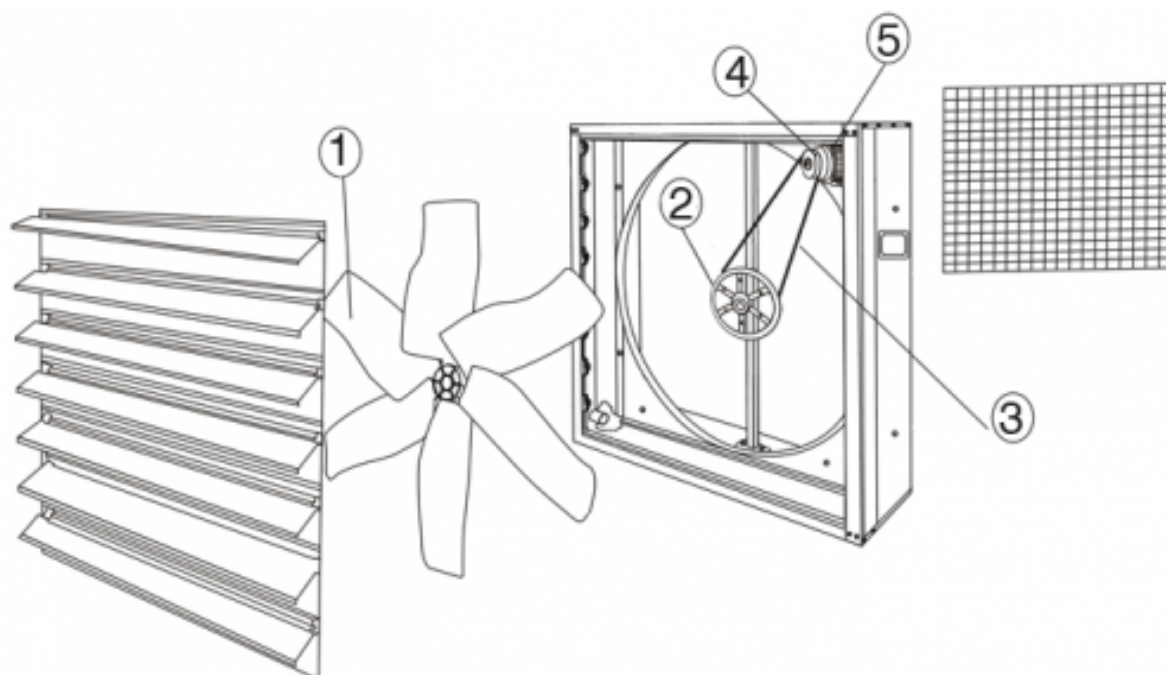

	Code	Model	Qty
1	509111044SP71	IMPELLER HJB 110	x1
2	509111044SP52	PULLEY+BEARING HJB110/120/140	x1
3	509111044SP21	BELT HJB110 B1829mm	x1
4	509111044SP31	PULLEY HJB110 B108mm	x1
5	509111044SP41	MOTOR 0,75kW T4 B3 230/400V (HJB)	x1