

HJB 140 T4 1,1KW (509113845)

GENERAL DATA



BELT DRIVE AXIAL FAN FOR HUGE AIR FLOW

MANUFACTURING FEATURES:

- Completely made of galvanized steel sheet.
 - Equipped with gravity shutter.
 - Stainless steel impeller (AISI 430).
 - Protection grid on pulley area.
 - Standard asynchronous squirrel-cage motor with IP-55 protection and class F insulation.
- Manufactured with standard voltage: 230/400V 50Hz IE3
- Internal wiring box. Inspection door for motor access.

APPLICATIONS:

Designed for wall assembly, they are suitable for:

- Air renewal in buildings and industries.
- Farms and greenhouses.
- Maximum working temperature: 50°C.

UNDER REQUEST

Option 60Hz

PERFORMANCE CURVE

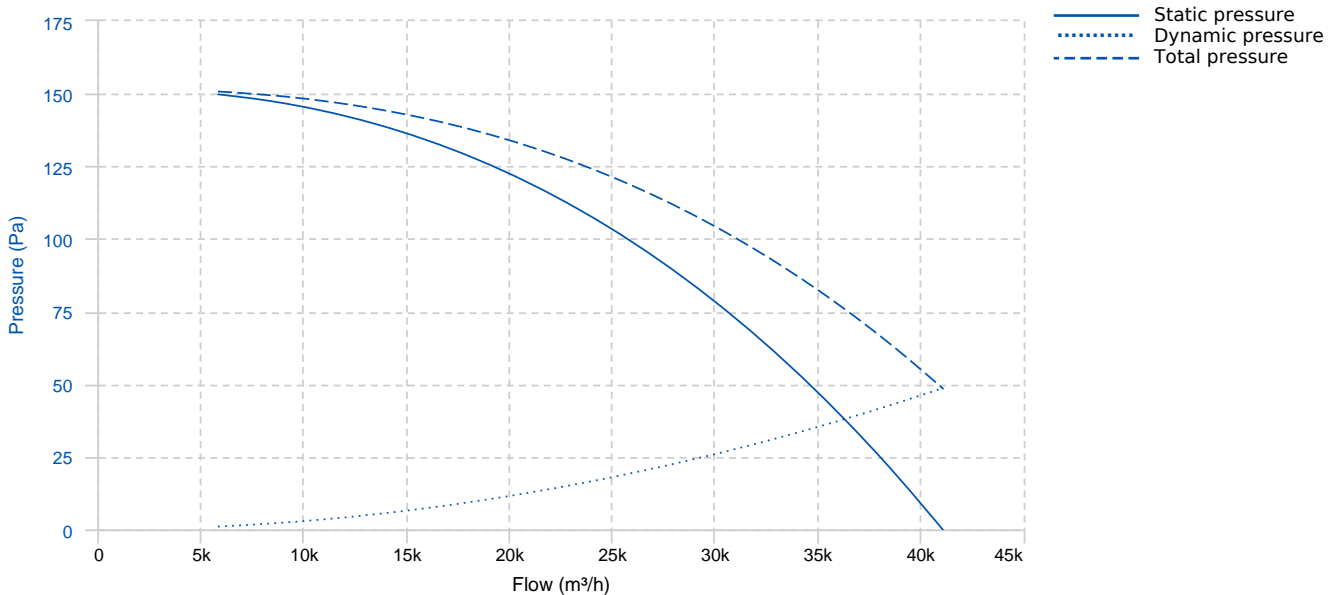

TECHNICAL DATA

Fan							
RPM	1450	Approx. weight	110 kg	Max. Flow	41100 m³/h		
Motor							
Power	1,1 kW	RPM	1450	I max. (230V)	4,7 A	I max. (400V)	2,7 A
Size	90S	Approx. weight	11.5 kg	Efficiency (%)	82.4 %	FP	0.72

DIMENSIONS

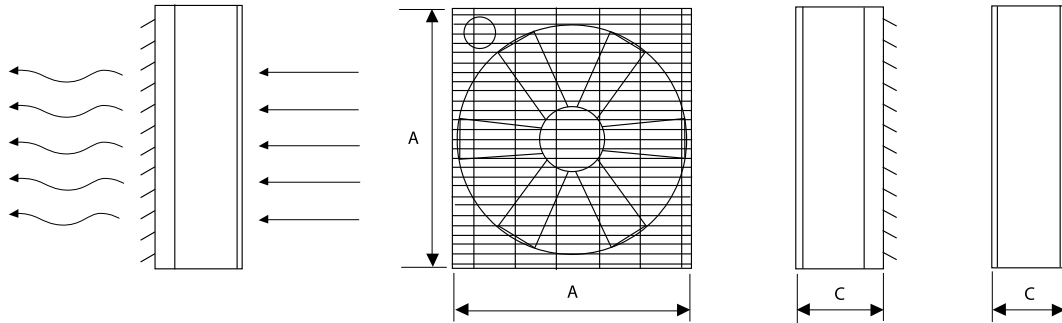

Dimensions (mm)

A	1380	C	400
---	------	---	-----

WIRING DIAGRAM

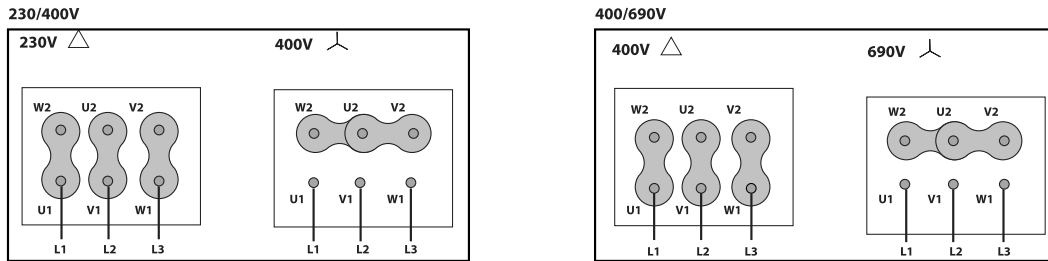

ACCESSORIES



SAFETY SWITCH
INT 25 3P A
REF: INT253PA

SPARE PARTS

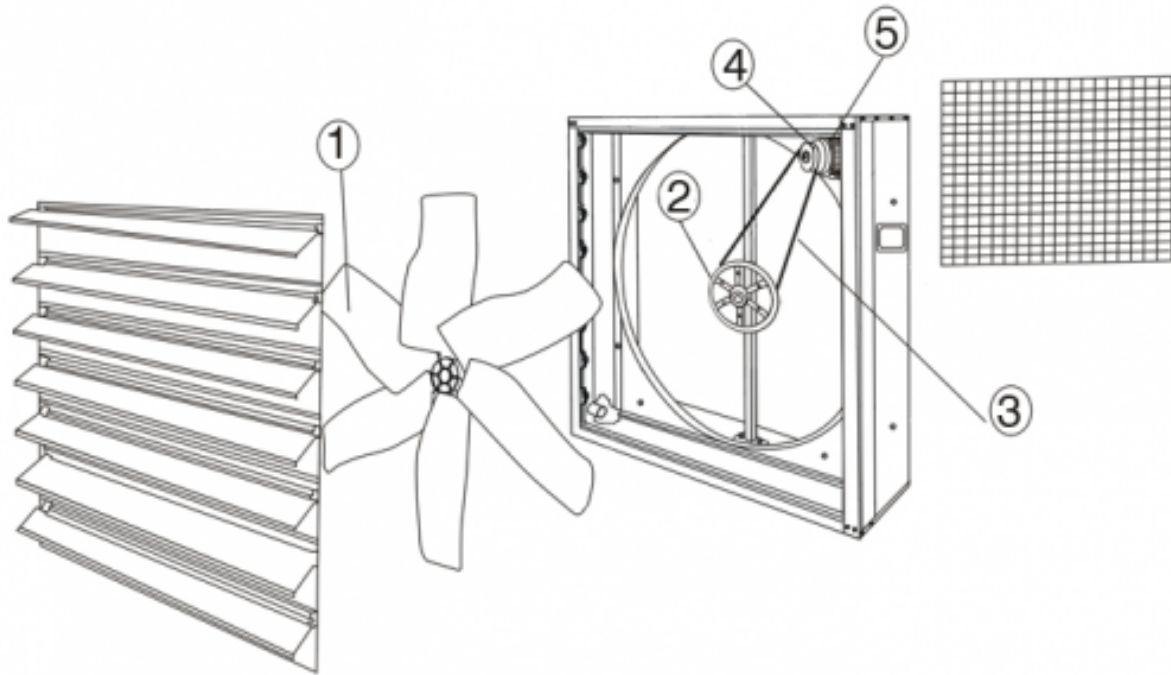

	Code	Model	Qty
1	509113845SP71	IMPELLER HJB 140	x1
2	509111044SP52	PULLEY+BEARING HJB110/120/140	x1
3	509113845SP21	BELT HJB140 B2134mm	x1
4	509112244SP31	PULLEY HJB120/140 B90mm	x1
5	509112244SP41	MOTOR 1,1kW T4 B3 230/400V (HJB)	x1