

HJBM PLUS 30 M2 0,55kW (268303103)

GENERAL DATA



SQUARE WALL PLATE FAN, VARIABLE PITCH BLADES AND HIGH EFFICIENCY MOTOR

MANUFACTURING FEATURES

- Square plate made of galvanized steel sheet with polyester painting.
- Variable pitch angle polyamide impeller reinforced with fibreglass.
- Supplied with motor support and protection guard according to the UNE-EN 20-359-74 norm and the ROHS 2002/95/EC Directive (Restriction of the Use of Certain Hazardous Substances in Electrical and Electronic Equipments).
- High efficiency standard asynchronous squirrel-cage motor with IP-55 or IP-54 protection (wiring box IP-65) and Class F insulation. Manufactured with standard voltages: 230V 50Hz for the single phase motors and 230/400V 50Hz for the three phase motors.

APPLICATIONS

Designed for wall assembly, they are suitable for:

- Air renewal in buildings and industries.
- Maximum working temperature: single phase 50°C, three phase 60°C.

UNDER REQUEST

- Aluminium impeller.
- 60Hz fans.

PERFORMANCE CURVE

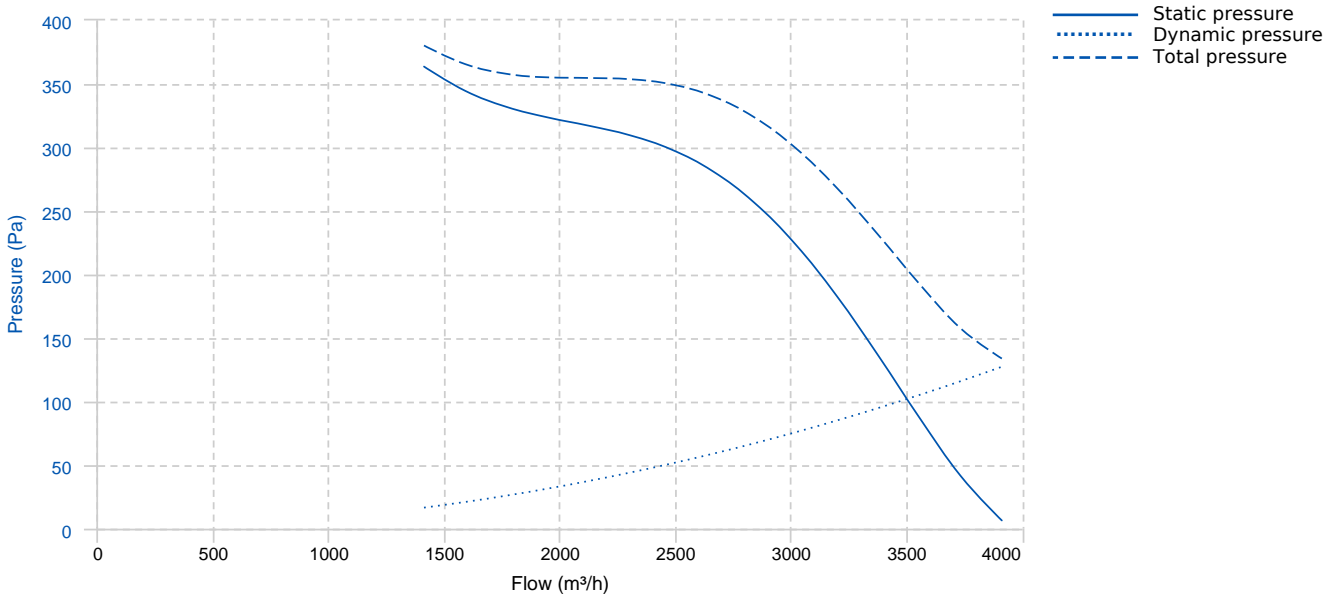

TECHNICAL DATA

Fan							
RPM	2800	Approx. weight	6.5 kg	Max. Flow	3920 m³/h		
Motor							
Power	0,55 kW	RPM	2800	Capacitor	20µF 450V	I max. (230V)	3,71 A
Size	71	Approx. weight	6.7 kg	Efficiency (%)	70 %	FP	0.92

DIMENSIONS

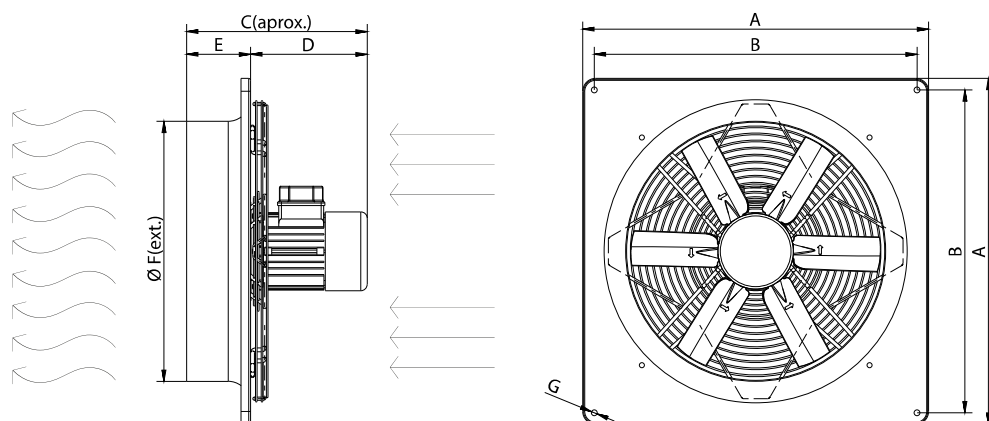

Dimensions (mm)

A	404	B	337	C	298,5	D	220,5	E	82
ØF	308	ØG	9						

WIRING DIAGRAM

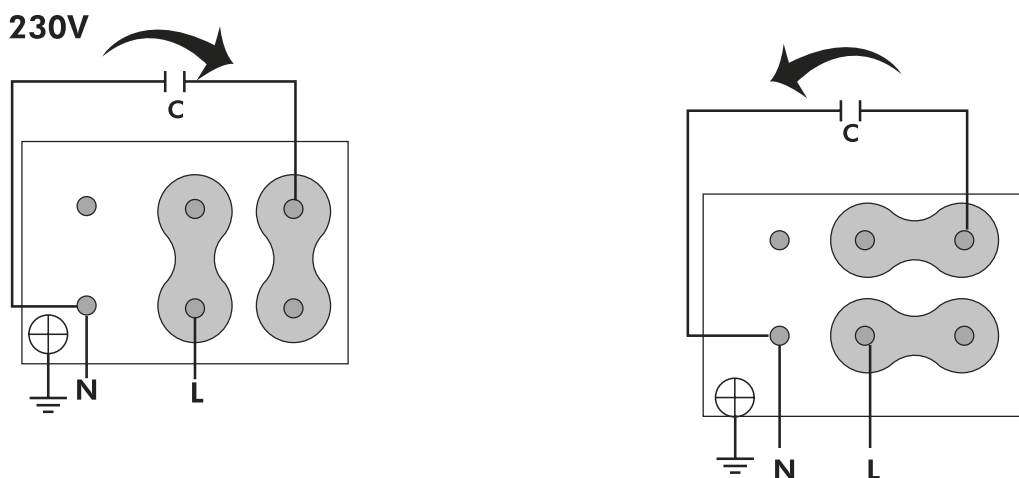

ACCESSORIES



SAFETY SWITCH
INT 25 3P A
REF: INT253PA



Outlet protection guard for axial fans
RPO 30
REF: 980000030



PLASTIC GRAVITY SHUTTER
PCP 30
REF: 963220105G



ALUMINIUM GRAVITY SHUTTER
PC2 30
REF: PC23030

SPARE PARTS

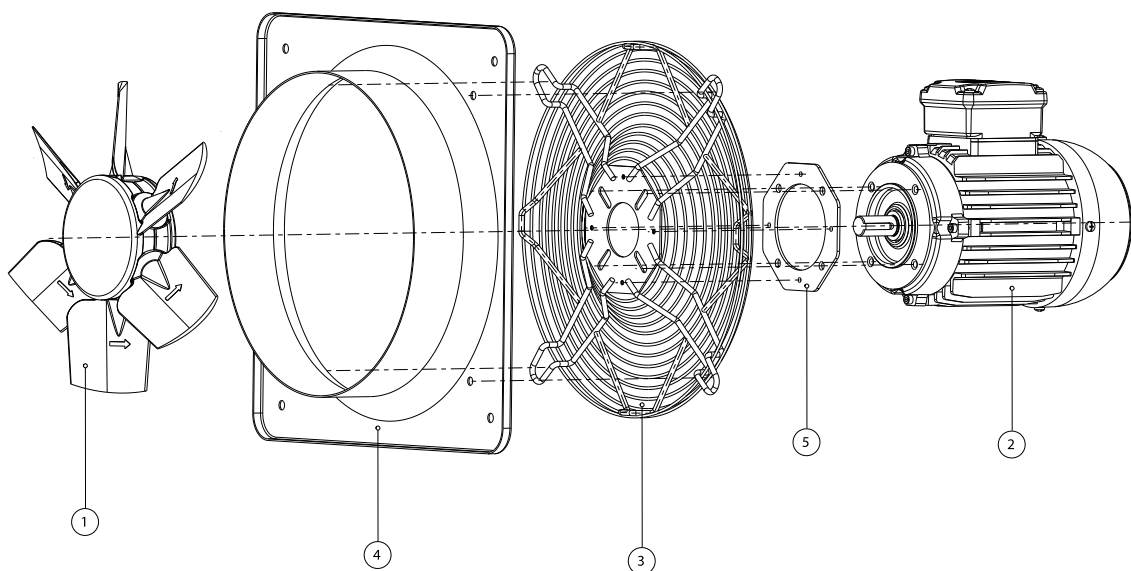

	Code	Model	Qty
1	R-H30006235PSTD	IMPELLER 300:AP0:6 G35 D14	x1
2	720301040	MOTOR 0,55kW M2 B14 230V	x1
3	R-268301902	PROTECTION GRID HJBM30	x1
4	R-265311778A001	FRAME HJEM-HJBM30	x1
5	R-268351909	SUPPORT MOTOR DISC HJBM25-30-35-40-45 T.71	x1