

HJBM PLUS 56 T4 0,75kW (268563106)

GENERAL DATA



SQUARE WALL PLATE FAN, VARIABLE PITCH BLADES AND HIGH EFFICIENCY MOTOR

MANUFACTURING FEATURES

- Square plate made of galvanized steel sheet with polyester painting.
- Variable pitch angle polyamide impeller reinforced with fibreglass.
- Supplied with motor support and protection guard according to the UNE-EN 20-359-74 norm and the ROHS 2002/95/EC Directive (Restriction of the Use of Certain Hazardous Substances in Electrical and Electronic Equipments).
- High efficiency standard asynchronous squirrel-cage motor with IP-55 or IP-54 protection (wiring box IP-65) and Class F insulation. Manufactured with standard voltages: 230V 50Hz for the single phase motors and 230/400V 50Hz for the three phase motors.

APPLICATIONS

Designed for wall assembly, they are suitable for:

- Air renewal in buildings and industries.
- Maximum working temperature: single phase 50°C, three phase 60°C.

UNDER REQUEST

- Aluminium impeller.
- 60Hz fans.

PERFORMANCE CURVE

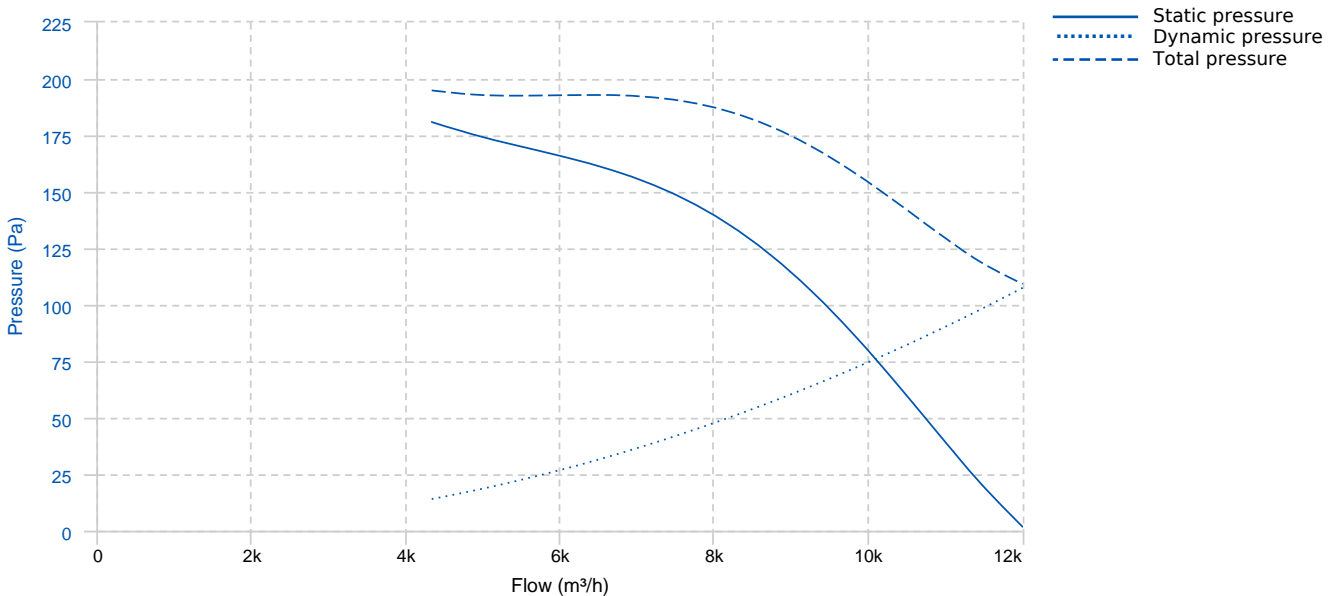

TECHNICAL DATA

Fan							
RPM	1410	Approx. weight	20 kg	Max. Flow	12010 m³/h		
Motor							
Power	0,75 kW	RPM	1410	I max. (230V)	2,83 A	I max. (400V)	1,63 A
Size	80	Approx. weight	15 kg	Efficiency (%)	82.5 %	FP	0.81

ERP DATA

Fan data sheet		
Fan type	Axial fan	
Installation category	A: Outlet and Inlet free discharge	
Efficiency category	Static	
The fan has to be installed with VF	No	
Motor power (kW)	0.75	
	Fan values	ERP Requirements 2015
Max. efficiency (%)	39.66	32.97
Efficiency grade (N)	46.69	40
Pabs (kW)	0.773	
Flow (m ³ /h)	7284.53	
Static pressure (Pa)	151.99	
Speed (m/s)	1410	
Specific ratio	1.00	

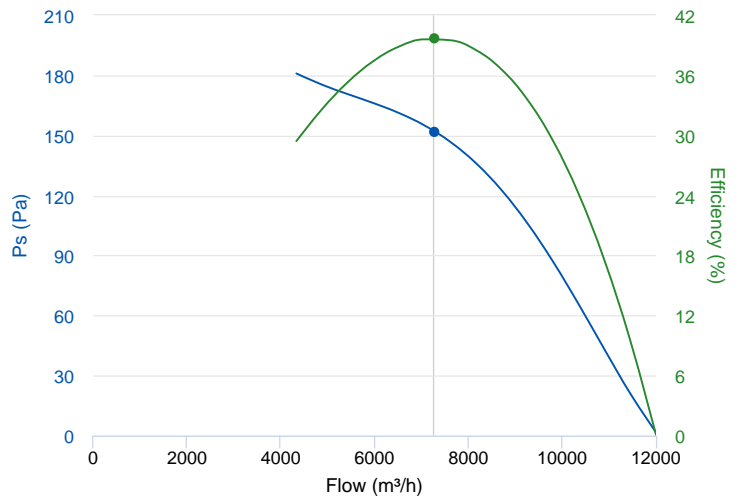

DIMENSIONS

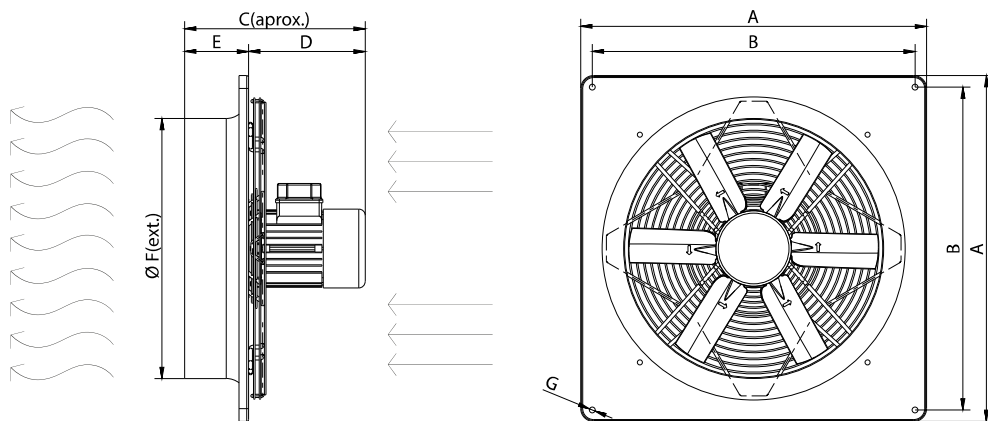

Dimensions (mm)

A	725	B	650	C	339,5	D	219,5	E	120
ØF	560	ØG	11						

WIRING DIAGRAM

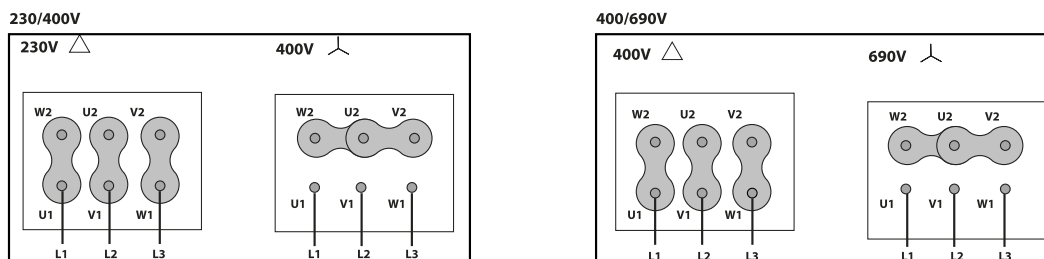

ACCESSORIES



SAFETY SWITCH
INT 25 3P A
REF: INT253PA



Outlet protection guard for axial fans
RPO 56
REF: 980000056



PLASTIC GRAVITY SHUTTER
PCP 56
REF: 963250105G



ALUMINIUM GRAVITY SHUTTER
PC2 60
REF: PC26060



FREQUENCY SPEED CONTROLLER
SFC 230 I 4,2A *
REF: SFC230I004



FREQUENCY SPEED CONTROLLER
SFC 400 III 2,2A *
REF: SFC400III2

SPARE PARTS

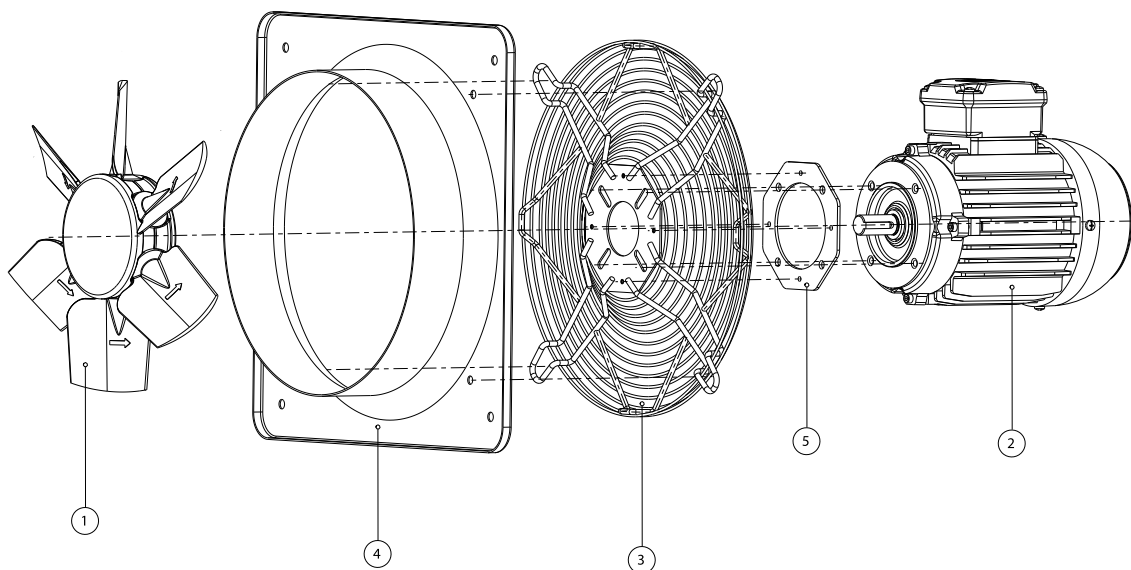

	Code	Model	Qty
1	R-H56006345PSTD	IMPELLER 560:AP0:6 G45 D19	x1
2	721001141WEG	MOTOR 0,75kW T4 B14 230/400V	x1
3	R-268561902	PROTECTION GRID HJBM56	x1
4	R-268561779A001	FRAME HJBM-HJBM EEC56	x1
5	R-268561909	SUPPORT MOTOR DISC HJBM50-56 T.80	x1