

MAX 27 T2 0,55kW Zone 2: FAN (Ex h IIB T3 Gc) + MOTOR (Ex ec IIC T3 Gc) (300318200XN)

GENERAL DATA



CENTRIFUGAL MEDIUM PRESSURE ATEX FAN

MANUFACTURING FEATURES

- Cast aluminium housing.
- Cast aluminium impeller.
- Polyester powder finishing coat.
- ATEX standard asynchronous motor. ATEX certified according to the zone. IP55 protection and class F insulation. Manufactured with standard voltages: 230/400V 50Hz for three phase motors.

- Available positions (to be indicated in case of order): LG270, LG0, LG45, LG90, LG135, LG180, LG315.
- The indicated codes correspond to the model in position LG270

APPLICATIONS

Designed for inline installation, they are suitable for:

- Ventilation in indoor environments classified as ATEX
- Working temperature: ambient from -20°C to 40°C, transported air according to the ATEX classification.

UNDER REQUEST

- 60Hz fans and special voltages.

ORGANISM: L.O.M.

CERTIFICAT N°: LOM 17.407N-C

In compliance with the Directive 2014/34/UE

PERFORMANCE CURVE

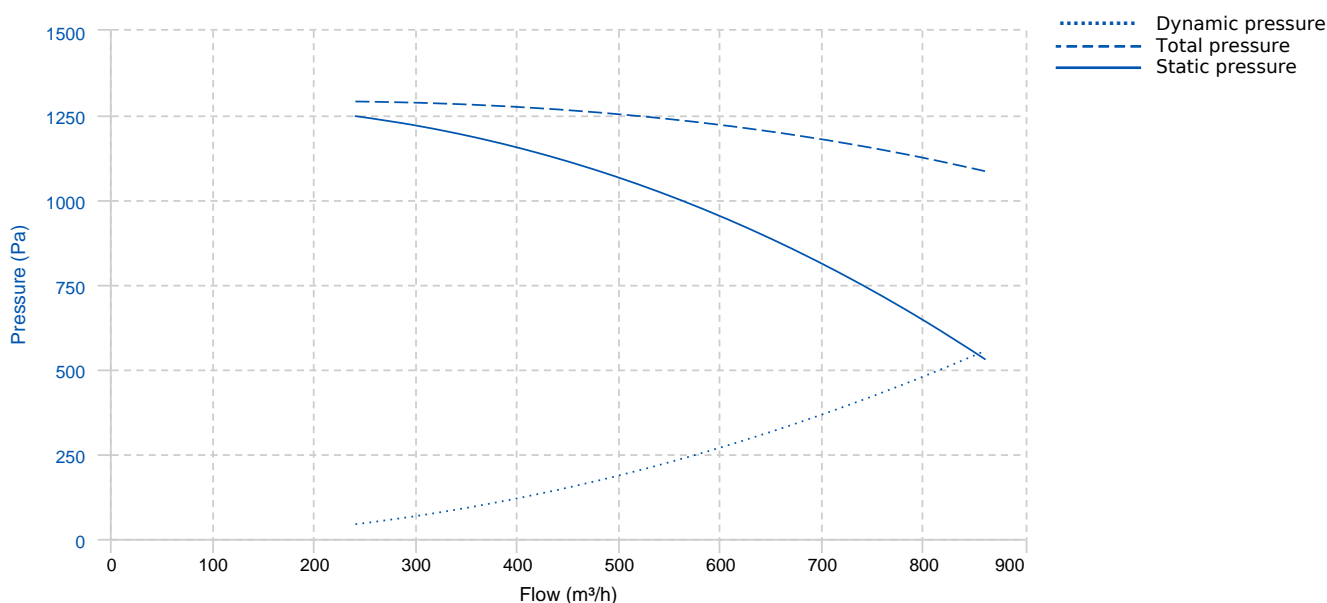

TECHNICAL DATA

| Fan | | | | | | | |
|----------------|---------|----------------|-------|---------------|-----------------------|------|----|
| RPM | 2840 | Approx. weight | 14 kg | Max. Flow | 870 m ³ /h | | |
| Motor | | | | | | | |
| Power | 0,55 kW | RPM | 2840 | I max. (400V) | 1,45 A | Size | 71 |
| Approx. weight | 6.5 kg | Efficiency (%) | 70 % | FP | 0.78 | | |

DIMENSIONS

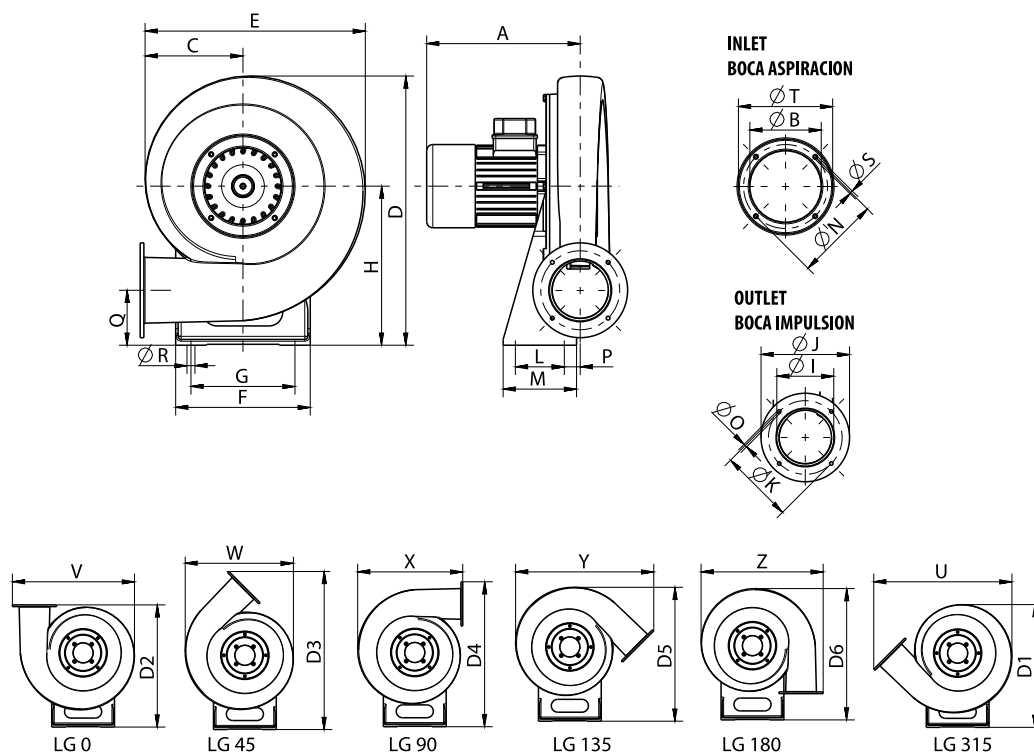

| Dimensions (mm) | | | | | | | | | |
|-----------------|-----|----|-----|----|-----|----|-----|----|-----|
| A | 250 | BØ | 125 | C | 168 | D | 440 | D1 | 431 |
| D2 | 428 | D3 | 552 | D4 | 505 | D5 | 470 | D6 | 460 |
| E | 368 | F | 220 | G | 170 | H | 260 | IØ | 100 |
| J | 155 | L | 80 | M | 120 | NØ | 147 | OØ | 6,2 |
| P | 26 | Q | 90 | RØ | 13 | SØ | M6 | TØ | 165 |
| U | 482 | V | 425 | W | 381 | X | 168 | Y | 482 |
| Z | 425 | ØK | 129 | | | | | | |

WIRING DIAGRAM

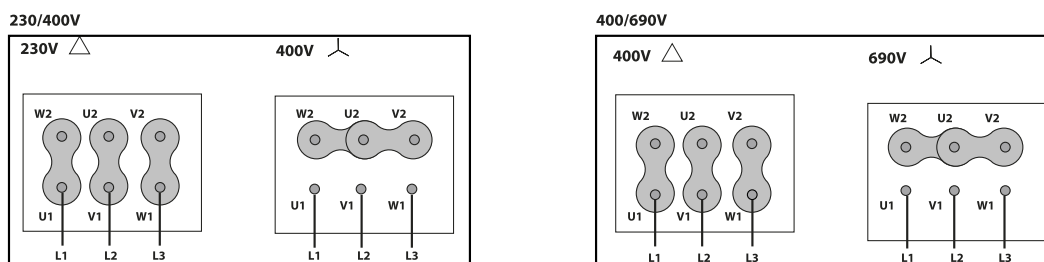

ACCESSORIES



INLET PROTECTION GUARD FOR CENTRIFUGAL FANS
RA 14/5
REF: A-253101901



ANTI-VIBRATION JOINT
JE 45
REF: A-300719201



OUTLET PROTECTION GUARD
RBS 27
REF: A-960000381



ATEX SWITCH
INT 16 ATEX
REF: 510200016X



FREQUENCY SPEED CONTROLLER
SFC 400 III 2,2A *
REF: SFC400III2



ANTI-VIBRATION SPRING BLOCK
AVS (GENERIC)



ANTI-VIBRATING FLANGE 400^º/2H
BA-400 15/16
REF: 960002067



CONNECTION FLANGE
AC 130
REF: 960003203



CIRCULAR-CIRCULAR ANTI-VIBRATION FLANGE
BAD 3 (Ø130)
REF: 960003453



FREQUENCY SPEED CONTROLLER
SFC 230 I 4,2A *
REF: SFC230I004



ANTI-VIBRATION RUBBER BLOCK
AVR (GENERIC)



ACOUSTIC CABINS FOR CENTRIFUGAL FANS
AB (GENERIC)

SPARE PARTS

| | Code | Model | Qty |
|---|-------------|-------------------------|-----|
| 1 | R-153403651 | IMPELLER MA27 LG | x1 |
| 3 | R-153401771 | CASING MA27 | x1 |
| 4 | R-153401751 | BASE SUPPORT MOTOR MA27 | x1 |