

MAX 31 T2 2,2kW Zone 2: FAN (Ex h IIB T3 Gc) + MOTOR (Ex ec IIC T3 Gc) (253430106XN)

GENERAL DATA



CENTRIFUGAL MEDIUM PRESSURE ATEX FAN

MANUFACTURING FEATURES

- Cast aluminium housing.
- Cast aluminium impeller.
- Polyester powder finishing coat.
- ATEX standard asynchronous motor. ATEX certified according to the zone. IP55 protection and class F insulation. Manufactured with standard voltages: 230/400V 50Hz for three phase motors.

- Available positions (to be indicated in case of order): LG270, LG0, LG45, LG90, LG135, LG180, LG315.
- The indicated codes correspond to the model in position LG270

APPLICATIONS

Designed for inline installation, they are suitable for:

- Ventilation in indoor environments classified as ATEX
- Working temperature: ambient from -20°C to 40°C, transported air according to the ATEX classification.

UNDER REQUEST

- 60Hz fans and special voltages.

ORGANISM: L.O.M.

CERTIFICAT N°: LOM 17.407N-C

In compliance with the Directive 2014/34/UE

PERFORMANCE CURVE

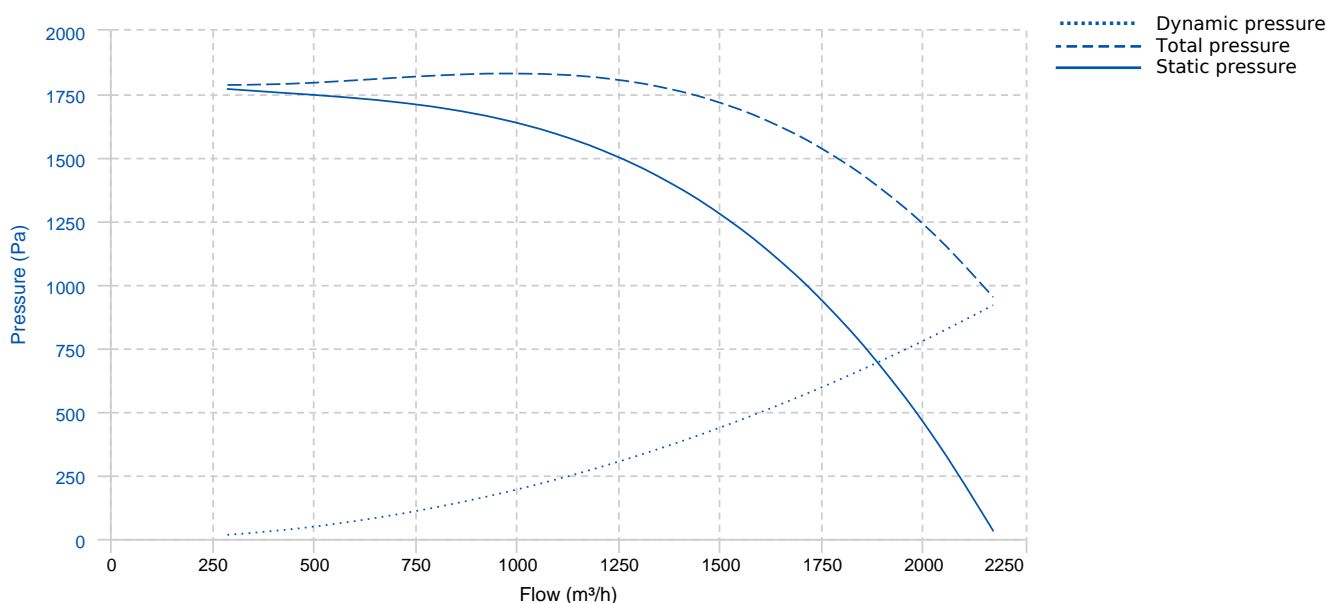

TECHNICAL DATA

Fan							
RPM	2840	Approx. weight	30 kg	Max. Flow	2180 m ³ /h		
Motor							
Power	2,2 kW	RPM	2840	I max. (400V)	5,4 A	Size	90L
Approx. weight	15 kg	Efficiency (%)	79 %	FP	0.8		

DIMENSIONS

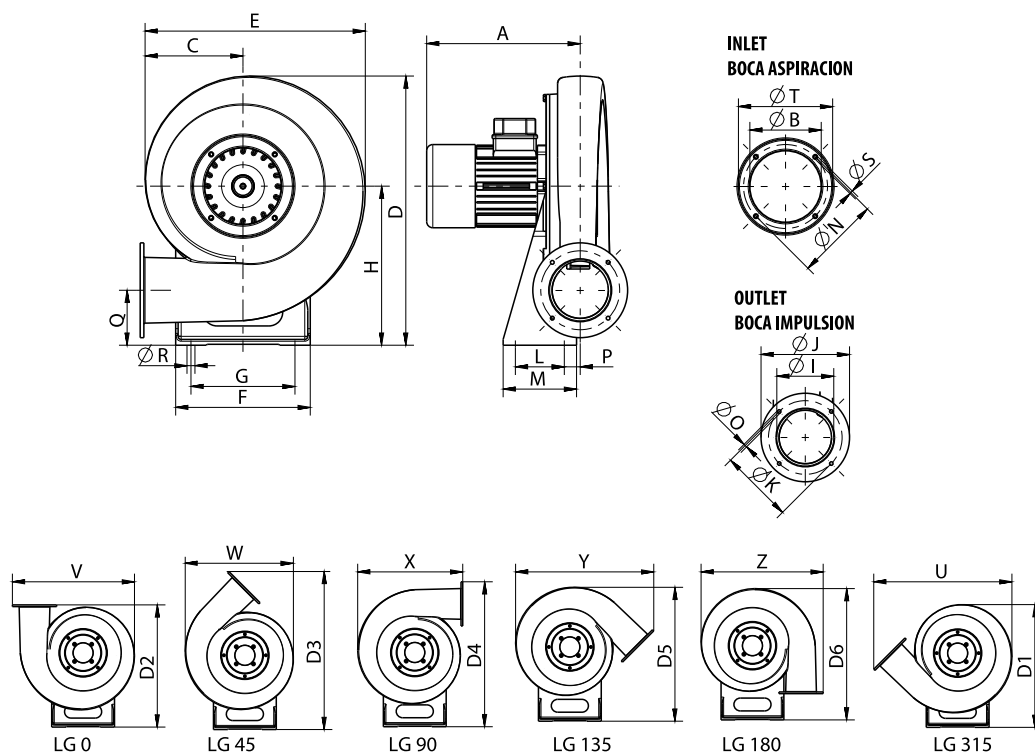

Dimensions (mm)									
A	320	BØ	160	C	193	D	530	D1	518
D2	513	D3	668	D4	620	D5	568	D6	555
E	428	F	240	G	190	H	323	IØ	145
J	200	L	120	M	160	NØ	180	OØ	10,2
P	18,5	Q	122	RØ	13	SØ	M6	TØ	215
U	570	V	510	W	445	X	428	Y	570
Z	510	ØK	175						

WIRING DIAGRAM

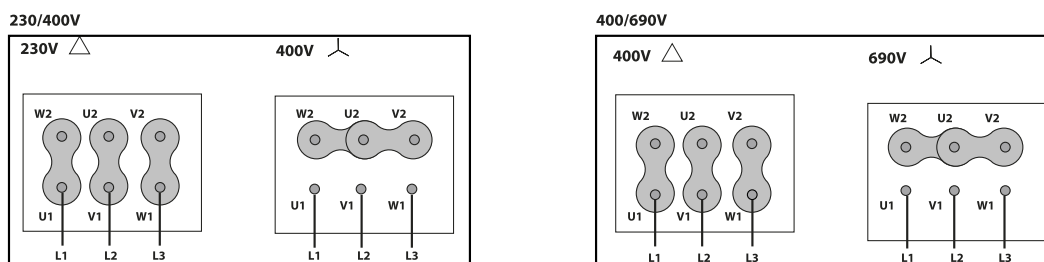

ACCESSORIES



INLET PROTECTION GUARD FOR CENTRIFUGAL FANS
RA 16/6
REF: A-253111901



ANTI-VIBRATION JOINT
JE 45
REF: A-300719201



OUTLET PROTECTION GUARD
RBS 31
REF: A-960000383



ATEX SWITCH
INT 16 ATEX
REF: 510200016X



FREQUENCY SPEED CONTROLLER
SFC 400 III 8A *
REF: SFC400III8



ANTI-VIBRATION SPRING BLOCK
AVS (GENERIC)



ANTI-VIBRATING FLANGE 400^º/2H
BA-400 15/16
REF: 960002067



CONNECTION FLANGE
AC 150
REF: 960003204



CIRCULAR-CIRCULAR ANTI-VIBRATION FLANGE
BAD 4 (Ø150)
REF: 960003454



FREQUENCY SPEED CONTROLLER
SFC 230 I 10A *
REF: SFC230I0010



ANTI-VIBRATION RUBBER BLOCK
AVR (GENERIC)



ACOUSTIC CABINS FOR CENTRIFUGAL FANS
AB (GENERIC)



SPARE PARTS

	Code	Model	Qty
1	R-153603651	IMPELLER MA31 LG	x1
3	R-153601771	CASING MA31	x1
4	R-153601751	BASE SUPPORT MOTOR MA31	x1