

MB 16/6 M4 0,08kW (253150103)

GENERAL DATA



MEDIUM PRESSURE CENTRIFUGAL FAN WITH FORWARD IMPELLER

MANUFACTURING FEATURES:

- Rolling steel sheet housing.
 - Completely joined or welded housing.
 - Galvanised steel sheet simple inlet forward curved impeller.
 - Polyester powder finishing coat.
 - Standard asynchronous squirrel-cage motor with IP-55 protection and Class F insulation.
- Manufactured with standard voltages: 230V 50Hz in single phase motors and 230/400V 50Hz in three phase motors.

- Available positions (to be indicated in case of order): LG270, LG0, LG45, LG90, LG135, LG180, LG225, LG315, RD0, RD45, RD90, RD135, RD180, RD225, RD270, RD315.
- The indicated codes correspond to the model in position LG270

APPLICATIONS:

Designed for inline installation, they are suitable for:

- Industrial applications, extraction or injection of air.
- Cooling of machines and parts.
- Suitable for transporting totally clean air without dust.
- Maximum working temperature: carried air: 130°C, environment single phase 50°C, three phase 60°C.

UNDER REQUEST:

- Special voltages.
- 2 speed motors (three phase motors).
- Fan for air working temperatures up to 250°C.
- Fans provided with cooling disk for high temperature.
- Option with support for models where it is not included, and without support for models where it is included.

PERFORMANCE CURVE

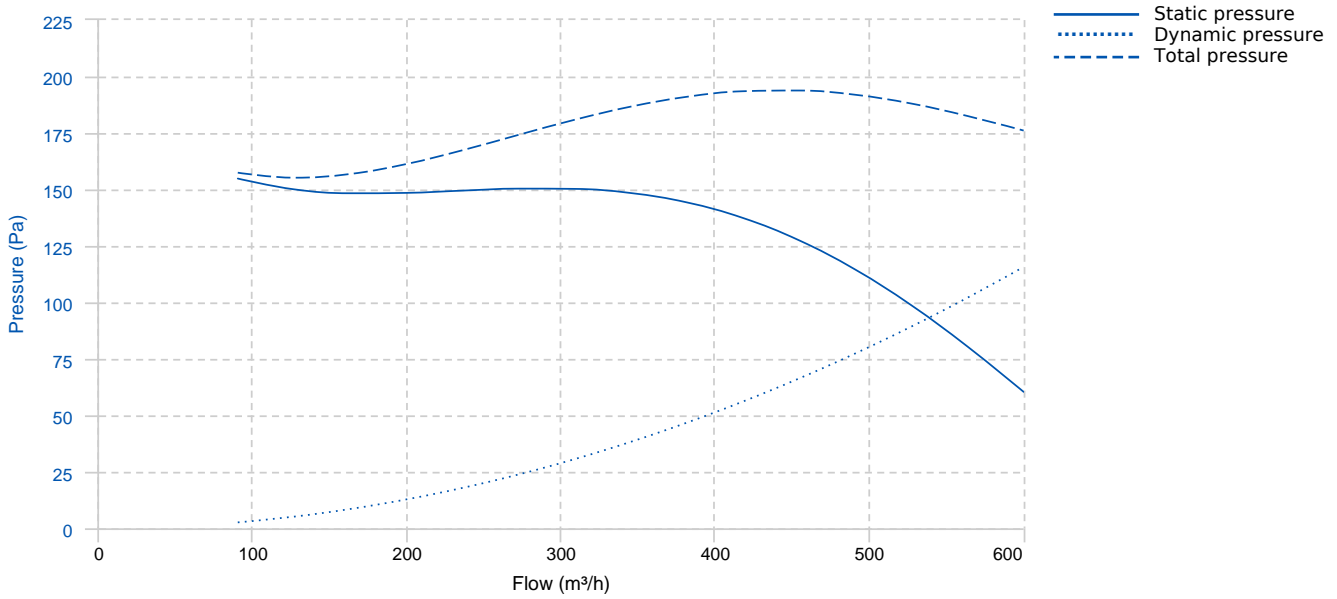

TECHNICAL DATA

Fan

RPM	1370	Approx. weight	7.5 kg	Max. Flow	600 m³/h
-----	------	----------------	--------	-----------	----------

Motor

Power	0,08 kW	RPM	1370	I max. (230V)	0,9 A
-------	---------	-----	------	---------------	-------

DIMENSIONS

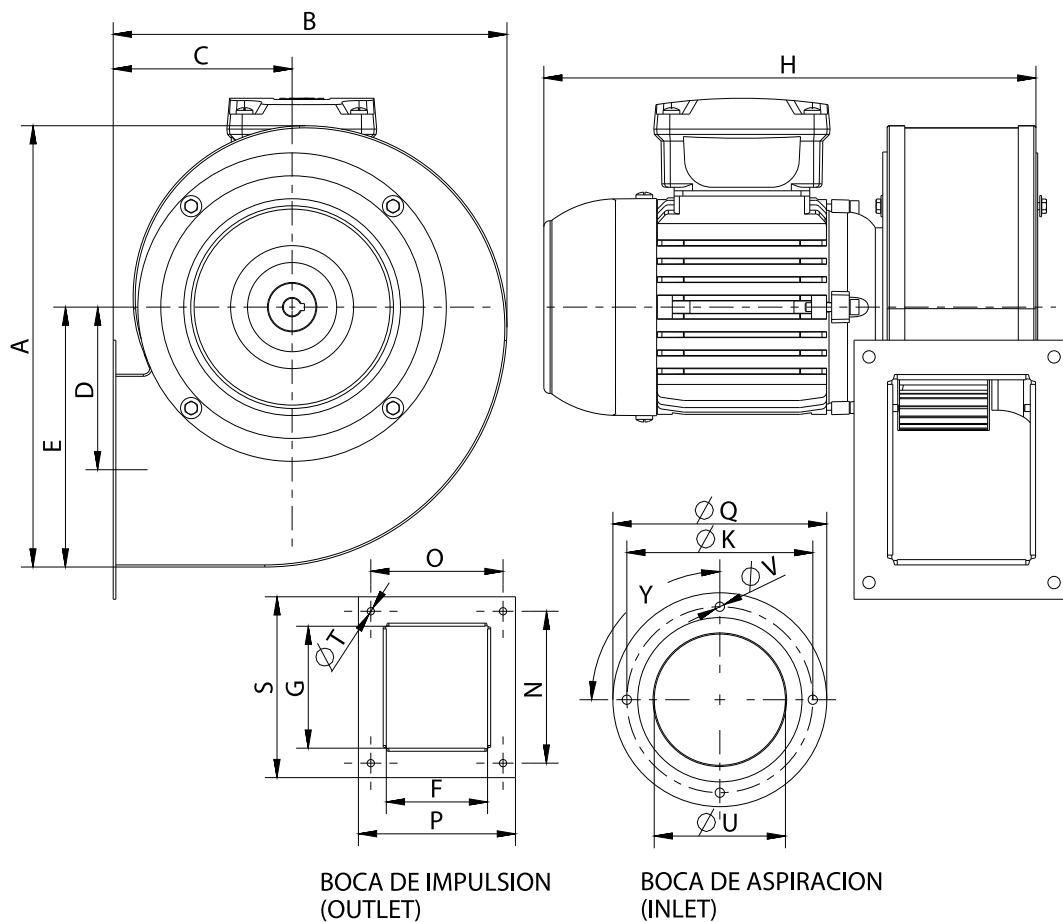

Dimensions (mm)

A	295	B	266	C	119	D	108,5	E	171,5
F	98	G	118	H	298	K	180	N	147
O	128	P	152	Q	207	S	175	TØ	7
UØ	127	VØ	9	Y	4x90°				

WIRING DIAGRAM

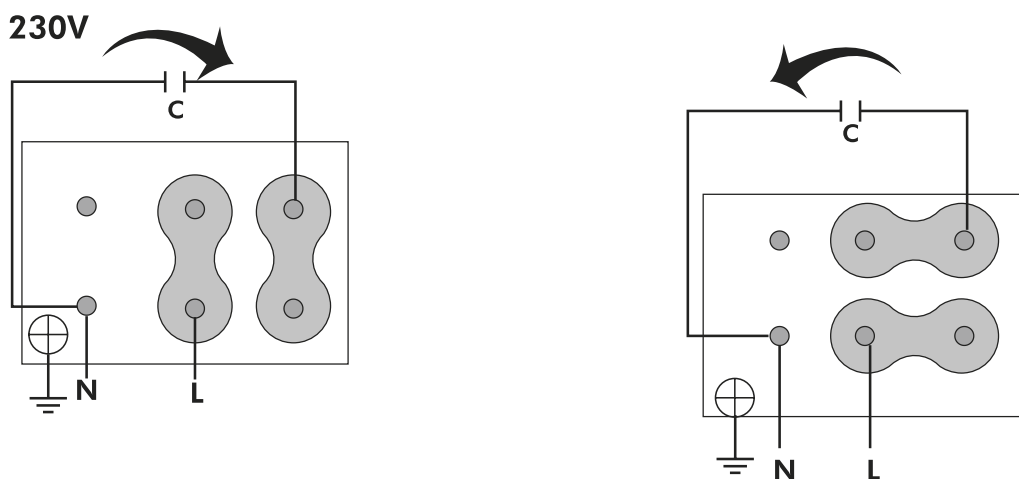

ACCESSORIES



SAFETY SWITCH
INT 25 3P A
REF: INT253PA



CIRCULAR OUTLET CONNECTION FLANGE
EI 16/6
REF: 962160111



ANTI-VIBRATION JOINT
JE 45
REF: 300719201



OUTLET PROTECTION GUARD
RBS 16/6
REF: A-960000354



INLET PROTECTION GUARD FOR CENTRIFUGAL FANS
RA 16/6
REF: A-253111901



ANTI-VIBRATING FLANGE 400^ø/2H
BA-400 15/16
REF: 960002067



CONECTION FLANGE
AC 150
REF: 960003204



ACOUSTIC CABINS FOR CENTRIFUGAL FANS
AB (GENERIC)

SPARE PARTS

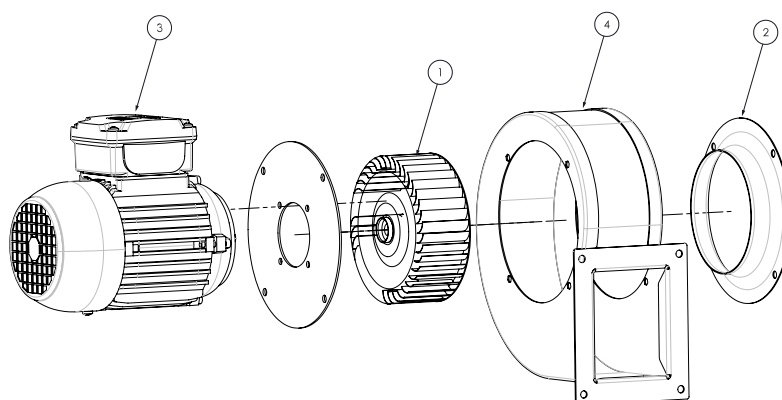

	Code	Model	Qty
1	R-253169388	TURBINE GALV.160X62X9 LG	x1
2	R-253111681	INLET CONE MB16/6	x1
3	720301100	MOTOR 0,04kW M4 B14 230V	x1
4	R-253119421	CASING MB 16/6	x1