

PREXTUR 314 T2 1,5kW (std) (PX314290)

GENERAL DATA

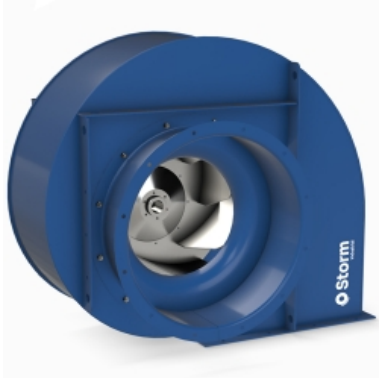

CENTRIFUGAL MEDIUM PRESSURE FAN FOR PAINT BOOTHS

MANUFACTURING FEATURES:

- Medium pressure centrifugal fan with direct coupling.
 - Reinforced housing made of carbon laminated steel, protected against corrosion by powder coating polyester resin RAL 5010. Finish C3.
 - Casing fully latched and adjustable.
 - Self-cleaning turbine and reinforced impeller with high-performance backward (reaction) blades made of carbon laminated steel dynamically balanced to minimize noise and vibrations. Black painted, RAL 9005
 - Squirrel cage standardized asynchronous IEC motor with IP-55 protection and class F electrical insulation. Standard voltages 230/400V 50Hz for three-phase motors up to 4kW and 400/690V 50Hz for higher powers.
 - Motor with flange (B5), airtight axle
 - Double suction flange
 - Maximum working temperature in continuous: transported air: 130°C, ambient: 60°C.
- Available positions (to be indicated in case of order): LG and RD
• The indicated codes correspond to the model in position LG

APPLICATIONS

Suitable for moving clean or dusty air. Designed to be fixed in the double suction flange, with the motor in vertical position.

- Paint booths
- Collection of dust
- Food industry dryers
- Food processing
- Incineration
- Odor control in industry
- Indoor / outdoor pollution control
- Big buildings
- Malls
- Factories / Industrial buildings
- Warehouses
- Extraction of smoke
- Boilers and ovens
- Manufacture and treatment of chemical products.
- Tunnels, underground stations.

ON DEMAND

- Fans for special voltages.
- 2 speed motor.
- C4 or C5 coating painting
- Hot dip galvanized
- Inox 304 (normal or electropolished finish)
- Inox 316 (normal or electropolished finish)
- Cooling wheel
- Anticaloric paint
- Fully welded housing (waterproof)
- Inspection door to facilitate maintenance and cleaning
- Drain plug.
- Non-sparking air passage and standard motor
- Other brands of motors.

PERFORMANCE CURVE

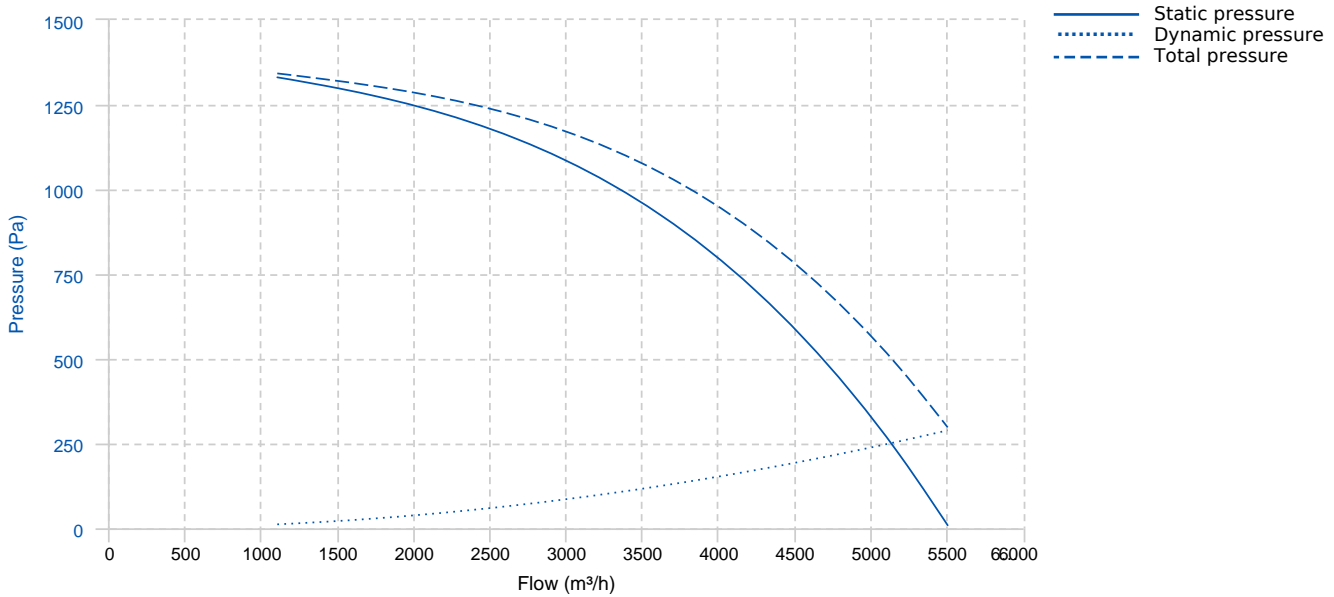

TECHNICAL DATA

Fan							
RPM	2865	Approx. weight	69.5 kg	Max. Flow	5510 m³/h		
Motor							
Power	1,5 kW	RPM	2865	I max. (230V)	5,83 A	I max. (400V)	3,14 A
Size	90L	Approx. weight	23.5 kg	Efficiency (%)	84.2 %	FP	0.83

ERP DATA

Fan data sheet		
Fan type	Centrifugal fan backward blades with casing	
Installation category	A: Outlet and Inlet free discharge	
Efficiency category	Static	
The fan has to be installed with VF	No	
Motor power (kW)	1.5	
	Fan values	ERP Requirements 2015
Max. efficiency (%)	66.74	52.04
Efficiency grade (N)	75.7	61
Pabs (kW)	1.401	
Flow (m³/h)	3134.41	
Static pressure (Pa)	1054.33	
Speed (m/s)	2865	

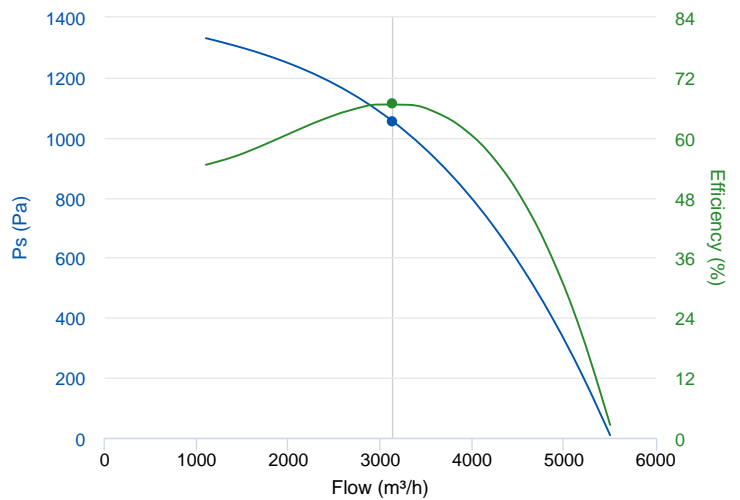

	Fan values	ERP Requirements 2015
--	-------------------	------------------------------

Specific ratio	1.01	
----------------	------	--

DIMENSIONS

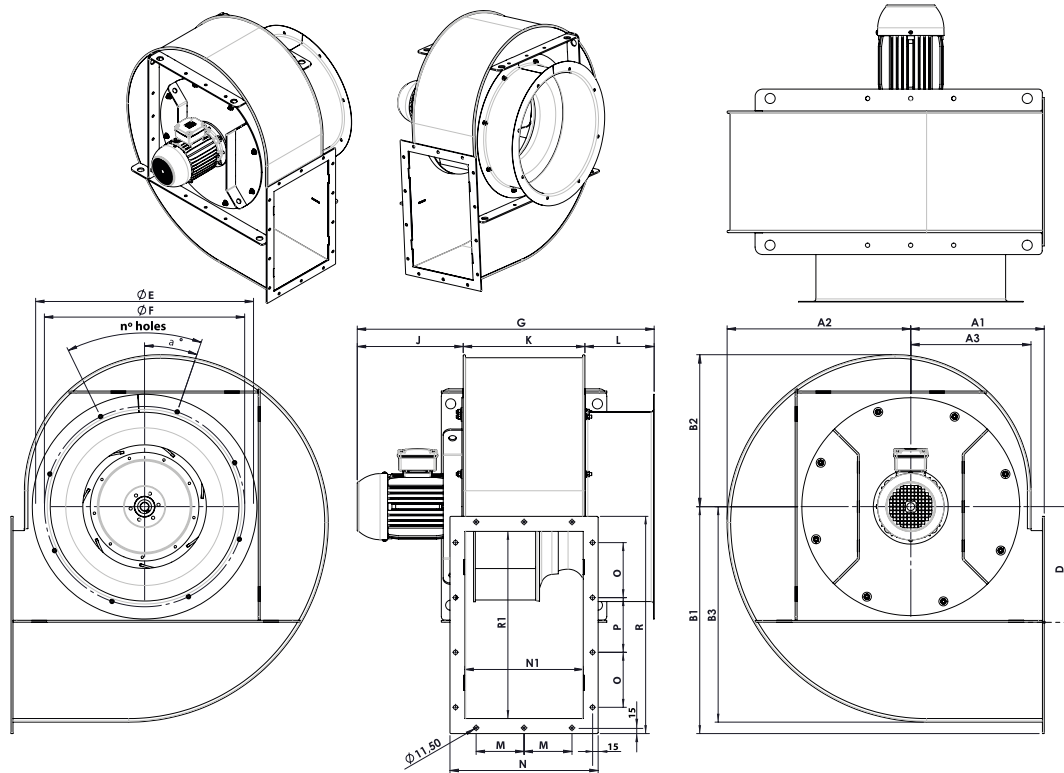

Dimensions (mm)									
A1	241.3	A2	312.6	A3	205.8	B1	396.5	B2	259.2
B3	366	D	199	E	377	F	355	G	693
J	278	K	230	L	185	M	91	N	301
N1	221	O	90	P	95	R	395	R1	315
a°	22,5°	n°holes	8x45°						

WIRING DIAGRAM

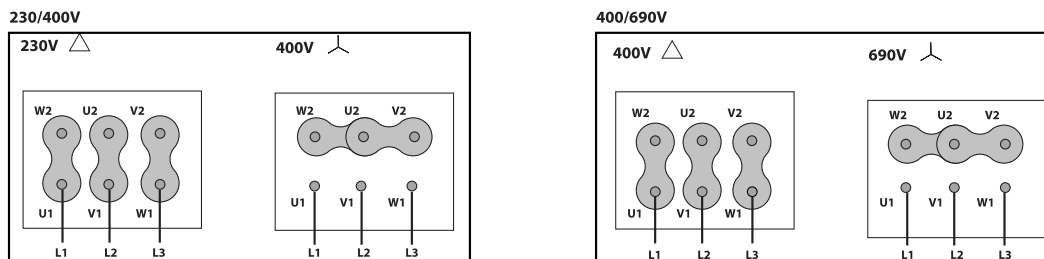

ACCESSORIES



SAFETY SWITCH
INT 25 3P A
REF: INT253PA



INLET PROTECTION GUARD FOR CENTRIFUGAL FANS
RA 31/12
REF: 253451901



ANTI-VIBRATING FLANGE 400°/2H
BA-400 30/31
REF: 960002052



ANTI-VIBRATION JOINT
JE 45
REF: 300719201



CONNECTION FLANGE
AC 300
REF: 960003209



OUTLET FLANGE FOR STORM MODELS
EIS 315x221-315
REF: EIS-3122131



CIRCULAR-CIRCULAR ANTI-VIBRATION FLANGE FOR STORM
BADS 315
REF: BADS-3131



OUTLET PROTECTION GUARD FOR STORM FANS
RIS 315x221
REF: RIS-31221E2

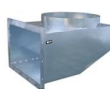

OUTLET BEND FOR STORM FANS
CPS 315x221-315
REF: CPS-3122131



RECTANGULAR-RECTANGULAR ANTI-VIBRATION FLANGE FOR STORM
BIDS 221x315-200
REF: BIDS-31221



FREQUENCY SPEED CONTROLLER
SFC 230 I 7A *
REF: SFC230I007



FREQUENCY SPEED CONTROLLER
SFC 400 III 3,6A *
REF: SFC400III4



ANTI-VIBRATION RUBBER BLOCK
AVR (GENERIC)



ANTI-VIBRATION SPRING BLOCK
AVS (GENERIC)



**ACOUSTIC CABINS FOR CENTRIFUGAL FANS
AB (GENERIC)**

SPARE PARTS

	Code	Model	Qty
1	R-BAD-N31	INLET CONE 315	x1
2	721001058	MOTOR 3kW T2 B5 230/400V	x1
3	721001047	MOTOR 1,5KW T2 B5 230/400V	x1