

REINTAIR® WARRIOR S 300 EC (REIN2-300ECW)

GENERAL DATA



PLUG & PLAY PURIFIERS TO TURN ANY INDOOR SPACE INTO A VIRUS-FREE ENVIRONMENT

MAIN FUNCTION

- REINTAIR® by Casals air purifiers are plug & play sets (no installation required) to convert any interior space into an environment free of contaminating particles and thus leave a much healthier air.
- It is designed to reduce the viral load of the rooms given the constant air renewals that it carries out.

REINTAIR® WARRIOR VERSIÓN:

- All REINTAIR® WARRIOR purifiers have the same equipment as REINTAIR® EC, but they also have the PHOTOCATALYSIS-UVC TOWER by Casals installed, consisting of a UV-C ultraviolet light lamp and a photocatalysis system that allows destroying the particles previously captured by the filters.
 - PHOTOCATALYSIS-UVC TOWER by Casals carries out a photocatalytic oxidation process that combines UVC irradiation with a substance (catalyst) titanium dioxide (TiO₂) which results in a reaction that changes harmful contaminants (bacteria, viruses and volatile organic compounds or VOC's) into H₂O, CO₂ and detritus.
 - The air purification process of using photocatalytic oxidation works by using an existing air system that pulls air through the REINTAIR® which passes through the professionally installed ultraviolet light/ titanium dioxide chamber. As the malignant contaminant-filled ambient air circulates through these chamber the microbes are "attacked" by free hydroxyl radicals and super-oxide ions (created by UV light and titanium dioxide) breaking their cellular structure apart and destroying both the intracellular mass and DNA/HNA chromosomes.
- The result is harmless water molecules, carbon dioxide and detritus.

MANUFACTURING FEATURES

- High efficiency purification unit built in soundproof steel structure, galvanized for corrosion resistance.
- Available in EC in two different sizes:
 1. REINTAIR® S EC up to 300m³/h for indoor spaces (2,5m high) of up to 45m².
 2. REINTAIR® L EC up to 600m³/h for indoor spaces (2,5m high) of up to 90m².

CHASIS:

- Soundproof 30mm extruded aluminum profile, nylon corners and pre lacquered steel sandwich panels, RAL 9006, class M0, with 25mm internal rockwool insulation class A1 (non combustible) and 90Kg/m³ density. Panels come with quick release fastening system for easy assembly and disassembly whenever required, whether for cleaning, maintenance or panel repositioning.
- Filters are located in the perforated side panels, with handles and fastening system. This ease of access optimizes maintenance and filter replacement procedures. Filter replacement and manipulation of the REINTAIR® WARRIOR is recommended with the appropriate PPE's.
- REINTAIR® purifiers are equipped with 4 wheels with brakes on the base for ease of mobility throughout the interior spaces.

FAN:

- Equipped with high efficiency single inlet - backward impeller with self-cleaning system, made of polyamide, statically and dynamically balanced at the factory.

FILTERS:

- Dual filtering stage at each end of the REINTAIR® WARRIOR comprised of 2x Iso Coarse 65% (G4) + 2x HEPA H14.
- 4 filters per purification unit.
- The Iso Coarse 65% pre-filters increase the life of the absolute filters HEPA H14.

MOTORS:

Low consumption EC (electronically commutated) Technology exterior rotor motor. IP-44 protection and class B insulation. Standard voltage 230V 50Hz/60Hz.

CONTROL PANEL:

- All REINTAIR® air purifiers are equipped with a master control panel located on one side of the structure.
- This control panel allows for control of the following parameters:
 1. On/Off of the air Purifier.
 2. Automatic function - Autonomous.
 3. Flow adjustment, 0 being the lowest and 10 the highest.
 4. Schedule control for night mode optimization and thus favouring low energy consumption when the interior spaces are empty.
 5. Clogged filter alarm and maintenance indication.

ADVANTAGES

Reduction of dust particles, odors and contaminating microorganisms. Thus creating a healthier environment. Ideal for people with allergies and asthma.
 Aside from a healthier work environment, our air purifiers reduce the need for cleaning by removing a large portion of the dust that is generated daily.
 Double filtration stage with two ABSOLUTE HEPA H14 filter packages and a Molecular filter that in a matter of hours will reduce a large number of particles in the air such as microorganisms, bacteria, viruses, molecules, etc.
 Equipped with high efficiency and silent fans to guarantee low energy consumption.

APPLICATIONS

- Designed for all kind of indoor spaces where high-quality air purification is required since REINTAIR® purifiers are equipped with high-efficiency HEPA H14 filters.
- Designed to be easily moved in indoor spaces, which makes them the best solution for:
 - Ventilation of workstations.
 - The health sector (waiting rooms, corridors, rooms, field hospitals, common areas, clinics, pharmacies, etc.).
 - The tertiary and industrial sector (offices, hotels, universities, schools, public institutions, warehouses, living rooms in restaurants).
 - The residential sector (single-family flats and houses).

[BUY REINTAIR WARRIOR](#)

TECHNICAL DATA

Fan							
RPM	3980	Approx. weight	30 kg	Max. Flow	300 m³/h		
Motor							
Power	0.134 kW	RPM	3980	I max. (230V)	1,08 A	Approx. weight	2.15 kg

DIMENSIONS

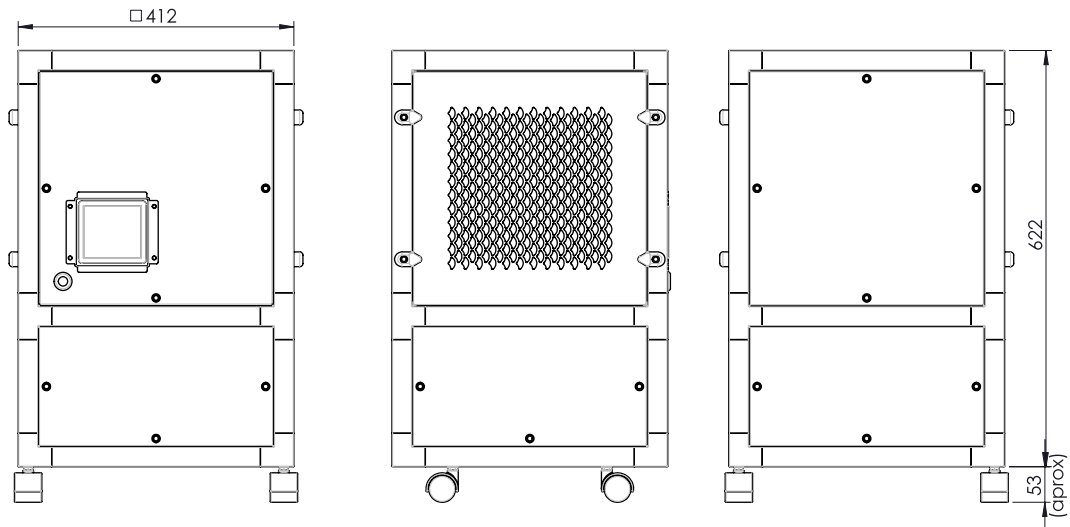

WIRING DIAGRAM

Nº	Signal Señal	Specification Especificación
1	L	AC 220V-50/60 Hz
2	N	AC 220V-50/60 Hz
3	Pe	

ACCESSORIES



ABSOLUTE FILTER FOR TERMINAL FILTRATION
FILT H14 (305x305x66-69) ABSOLUTO FLUJO
LAMINAR
REF: FILTH14005



CELL FILTER WITH GALVANIZED FRAME
FILT ISO Coarse ≥ 60% (287x287x20) PREFILTRO
MARCO CHAPA
REF: FILTG04003